

# **YANMAR**

## **MARINE DIESEL ENGINE**

**MODELS:  
4JH3-TE/-HTE/-DTE/-TCE Series**

### **OPERATION MANUAL**

**GB**

#### **California Proposition 65 Warning**

Diesel engine exhaust and some of its constituents are recognized by the State of California to cause cancer, birth defects, and other reproductive harm.

**YANMAR CO., LTD. LIMITED EMISSIONS CONTROL SYSTEM WARRANTY**

**Your Warranty Rights and Obligations:**

**California:**

The California Air Resources Board and Yanmar Co., Ltd. ("Yanmar") is pleased to explain the emission control system warranty on your off-road compression-ignition model year 2000 or later engine. In California, new heavy-duty off-road engines must be designed, built and equipped to meet the State's stringent anti-smog standards.

**All States**

Yanmar warrants that the engine is: (1) designed, built and equipped so as to conform with all applicable emissions regulations, including in California, all applicable regulations adopted by the Air Resources Board; and (2) free from defects in materials and workmanship which cause such engine to fail to conform with applicable emissions regulations for its warranty period.

Yanmar warrants the emission control system on your engine for the periods of time listed below provided there has been no abuse, neglect or improper maintenance of your engine. Your emission control system may include parts such as the fuel injection system and the air induction system. Also included may be hoses, belts, connectors and other emission-related assemblies.

**GB**

Where a warrantable condition exists, Yanmar will repair your heavy-duty off-road engine at no expense to you for diagnosis, parts or labor. Warranty services or repairs will be provided at a Yanmar authorized Dealer.

**Manufacturer's Warranty Period:**

The model year 2000 or later heavy-duty off-road engines are warranted for the periods listed below. If any emission-related part on your engine is defective, the part will be replaced by Yanmar.

Engine Type	Warranty Period by Number of Years or Hours of Operation
Engines rated at or above 19 kW	Warranty period is five (5) years or 3,000 hours of use, whichever occurs first. In the absence of a device to measure hours of use, the engine has a warranty period of five (5) years.
Engines rated under 19 kW	Warranty period is two (2) years or 1,500 hours of use, whichever occurs first. In the absence of a device to measure hours of use, the engine has a warranty period of two (2) years.
Constant speed engines rated under 37 kW with rated speeds greater than or equal to 3,000 min-1	Warranty period is two (2) years or 1,500 hours of use, whichever occurs first. In the absence of a device to measure hours of use, the engine has a warranty period of five (5) years,
Constant speed engines rated at or above 37 kW	Warranty period is five (5) years or 3,000 hours of use, whichever occurs first. In the absence of a device to measure hours of use, the engine has a warranty period of five (5) years.

### **Warranty Coverage:**

This warranty is transferable to each subsequent purchaser for the duration of the warranty period. Repair or replacement of any warranted part will be performed at an authorized Yanmar dealer.

Warranted parts not scheduled for replacement as required maintenance in the owner's manual shall be warranted for the warranty period. Any part repaired or replaced under warranty shall be warranted for the remaining warranty period. Warranted parts scheduled for replacement as required maintenance in the owner's manual are warranted for the period of time prior to the first scheduled replacement.

Yanmar is liable for damages to other engine components caused by the failure of any warranted part during the warranty period.

Any replacement part which is functionally identical to the original equipment part in all respects may be used in the maintenance or repair of your engine, and shall not reduce Yanmar's warranty obligations. Add-on or modified parts that are not exempted may not be used. The use of any non-exempted add-on or modified parts shall be grounds for disallowing a warranty.

### **Warranted Systems/ Parts Covered by this Warranty:**

- (1) Fuel Injection System
- (2) Cold start enrichment system
- (3) Intake manifold
- (4) Turbocharger Systems
- (5) Exhaust manifold

### **Exclusions:**

Failures other than those arising from defects in material or workmanship are not covered by this warranty. The Warranty does not extend to the following: malfunctions caused by abuse, misuse, improper adjustment, modification, alteration, tampering, disconnection, improper or inadequate maintenance, or use of non-recommended fuels or lubricating oils; accident-caused damage, or replacement of expendable items made in connection with scheduled maintenance. Yanmar disclaims any responsibility for incidental or consequential damages such as loss of time, inconvenience, loss of use of equipment/engine or commercial loss.

### **Owner's Warranty Responsibilities:**

**As the heavy-duty off-road engine owner, you are responsible for the performance of the required maintenance listed in your owner's manual.**

Yanmar recommends that you retain all documentation, including receipts, covering maintenance on your heavy-duty off-road engine, but Yanmar cannot deny warranty solely for the lack of receipts, or for your failure to ensure the performance of all scheduled maintenance.

Your engine is designed to operate on diesel fuel only. Use of any other fuel may result in your engine no longer operating in compliance with applicable emissions requirements.

You are responsible for initiating the warranty process. You must present your off-road engine to a Yanmar Dealer as soon as a problem exists. The warranty repairs should be completed by the Dealer as expeditiously as possible. If you have any questions regarding your warranty rights and responsibilities, or would like information on the nearest Yanmar Dealer/authorized service center, you should contact Yanmar Marine U.S.A. Corp. at Adairsville, GA U.S.A.

# Contents

## CONTENTS

INTRODUCTION .....	3	3.3 Operating your Engine .....	25
1 FOR YOUR SAFETY .....	4	3.3.1 Inspection Before Starting .....	25
1.1 Warning symbols .....	4	3.3.2 How to Start the Engine .....	27
1.2 Safety Precautions.....	4	3.3.3 Operation.....	28
1.3 Warning Labels .....	7	3.3.4 Cautions during Operation.....	29
2 PRODUCT EXPLANATION .....	8	3.3.5 Stopping the Engine .....	30
2.1 Use, Driving System etc.....	8	3.3.6 Procedure.....	31
2.2 Engine Specifications .....	10	3.4 Long term Storage.....	32
2.3 Names of Parts .....	13	4 MAINTENANCE & INSPECTION .....	34
2.4 Major Servicing Parts.....	14	4.1 General Inspection Rules .....	34
2.5 Control Equipment .....	15	4.2 List of Periodic Inspection Items .....	35
2.5.1 Control Panel.....	15	4.3 Periodic Inspection Items .....	37
2.5.2 Remote Control Handle.....	18	4.3.1 Inspection on Initial 50 Hrs. of Operation (or after 1 month)....	37
2.5.3 Stopping Equipment .....	19	4.3.2 Inspection Every 50 Hours (or monthly).....	38
3 OPERATION .....	20	4.3.3 Inspection Every 250 Hrs .....	39
3.1 Fuel Oil, Lube Oil & Cooling Water ....	20	4.3.4 Inspection Every 500 Hrs .....	42
3.1.1 Fuel Oil.....	20	4.3.5 Inspection Every 1000 Hrs .....	42
3.1.2 Lube Oil .....	20	5 TROUBLE AND TROUBLESHOOTING .....	43
3.1.3 Cooling Water.....	21	5.1 Trouble and Troubleshooting .....	43
3.2 Before Initial Operation .....	22	5.2 Emergency Repairs for Clutch .....	44
3.2.1 Supply Fuel Oil.....	22	6 PIPING DIAGRAMS .....	47
3.2.2 Bleeding the fuel system.....	22	7 WIRING DIAGRAMS .....	48
3.2.3 Supply Engine Lube Oil.....	22	APPENDIX A (Piping diagrams).....	A-1
3.2.4 Supply Clutch Lube Oil .....	23	(See the back of this Manual)	
3.2.5 Supply Cooling Water.....	23	APPENDIX B (Wiring diagrams) .....	B-1
3.2.6 Cranking (Idling).....	24	(See the back of this Manual)	
3.2.7 Check and Resupply Lube Oil and Cooling Water .....	25		

**GB**

## Introduction

**Thank you for purchasing a YANMAR Marine Diesel Engine.**

This Operation Manual describes the operation, maintenance and inspection of the 4JH3-TE/-HTE/-DTE/-TCE Series Yanmar Marine Diesel Engines.

Read this Operation Manual carefully before operating the engine to ensure that it is used correctly and that it stays in the best possible condition.

Keep this Operation Manual in a convenient place for easy access.

If this Operation Manual is lost or damaged, order a new one from your dealer or distributor.

Make sure this manual is transferred to subsequent owners. It should be considered as a permanent part of the engine and remain so.

Constant efforts are made to improve the quality and performance of Yanmar products, so some details included in this Operation Manual may differ slightly from your engine. If you have any questions about this, please contact your Yanmar dealer or distributor.

**GB**

Operation Manual (Marine Engine)	<b>Models</b>	<b>4JH3-TE/-HTE/-DTE/-TCE</b>
	<b>Code. No.</b>	<b>49961-202850</b>

# 1. For your safety

## 1.1 WARNING SYMBOLS

Most operation, maintenance and inspection problems arise due to users' failure to comply with the rules and precautions for safe operation described in this operation manual. Often, users do not understand or recognize the signs of approaching problems. Improper handling can cause burns and other injuries and can result in death.

Be sure to read this operation manual carefully before operating the engine and observe all of the instructions and precautions described in this manual.

Below follow the warning signs used in this manual and on the products. Pay special attention to parts containing these words and signs.



**DANGER** indicates an imminently hazardous situation which, if not avoided, **WILL** result in death or serious injury.

**GB**



**WARNING** indicates a potentially hazardous situation which, if not avoided, **COULD** result in death or serious injury.



**CAUTION** indicates a potentially hazardous situation which, if not avoided, **MAY** result in minor or moderate injury. This sign is also be used to alert against unsafe practices.

The descriptions captioned by **NOTICE** are particularly important cautions for handling. If you ignore them, the performance of your machine may deteriorate leading to problems.

## 1.2 SAFETY PRECAUTIONS

(Observe these instructions for your own safety!)

### Precautions for Operation

**⚠ DANGER**

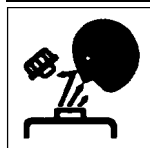

#### Filler Cap of Fresh Water Tank

Never open the cap of the fresh water tank while the engine is still hot. Steam and hot water will spurt out and burn you seriously. Wait until the temperature of the fresh water tank has dropped, wrap a cloth around the filler cap and loosen the cap slowly. After inspection, refasten the cap firmly.

# 1. For your safety

**⚠ DANGER**



**Battery**

Never smoke or permit sparks near the battery, because it may emit explosive hydrogen gas. Place the battery in a well-ventilated place.

**⚠ DANGER**



**Fuel**

Use only diesel oil. Never use other fuels, including gasoline, kerosene, etc., because they could cause a fire. The wrong fuel could also cause the fuel injection pump and injector to fail due to lack of proper lubrication. Be sure to check that you have selected the correct diesel fuel before filling the fuel tank.

**⚠ DANGER**



**Fire Prevention**

Be sure to stop the engine and confirm that there are no open flames in the vicinity before supplying fuel. If you do spill fuel, wipe such spillage carefully and dispose of the wiping materials properly. Wash your hands thoroughly with soap and water.

Never place oil or other flammable material in the engine room. Install a fire extinguisher near the engine room, and familiarize yourself with its use.

**⚠ WARNING**



**Exhaust Gas**

Exhaust gas contains poisonous carbon monoxide and should not be inhaled.

Be sure to install ventilation ports or ventilators in the engine room and ensure good ventilation during engine operation.

**⚠ WARNING**



**Moving Parts**

Do not touch or let your clothing get caught in the moving parts of the engine, such as the front drive shaft, V-belt or propeller shaft, during engine operation. You will be injured.

Never operate the engine without the covers on the moving parts. Before starting the engine, check to see that any tools or cloths used in maintenance have been removed from the area.

**⚠ CAUTION**



**Burns**

The whole engine is hot during operation and immediately after stopping. The turbocharger, intercooler, exhaust manifold, exhaust pipe and high pressure fuel pipe are very hot. Never touch these parts with your body or clothing.

**GB**

# 1. For your safety

## ⚠ WARNING



### Alcohol

Never operate the engine while you are under the influence of alcohol. Never operate the engine when you are ill or feeling unwell.

## SAFETY PRECAUTIONS FOR INSPECTION

## ⚠ DANGER



### Battery Fluid

Battery fluid is dilute sulfuric acid. It can blind you if it gets in your eyes, or burn your skin. Keep the fluid away from your body. If you touch it, wash it off immediately with a large quantity of fresh water and call your doctor for treatment.

## ⚠ WARNING



### Fire by Electric Short-Circuits

Always turn off the battery switch before inspecting the electrical system.

Failure to do so could cause short-circuiting and fires.

GB

## ⚠ WARNING



### Stop the engine before servicing

Stop the engine before you service it.

Turn the battery switch off. If you must inspect while the engine is in operation, never touch moving parts. Keep your body and clothing well clear of all moving parts.

## ⚠ CAUTION



### Scalds

If extracting oil from the engine while it is still hot, don't let the oil splash on you.

Wait until the temperature has dropped before extracting cooling water from the engine. Don't let it splash on you.

## ⚠ NOTICE

### Forbidden Modifications

Never release the limiting devices such as the engine speed limit, fuel injection limit, etc.

Modification will impair the safety and performance of the product and shorten product life.

Also note that any troubles arising from modification are not covered by our warranty.

## ⚠ NOTICE

### Precautions for Treating Waste

Never dispose of waste oil or other fluid in a field, sewer, river, or the sea. Treat waste matters safely observing regulations or laws.

Ask a waste recovery company to collect it.



# 1. For your safety

## SAFETY PRECAUTIONS FOR INSPECTION

### 1.3 WARNING LABELS

To insure safe operation, warning device labels have been attached. Their location is shown below and they should always be visible. Please replace if damaged or lost.

Product Safety Labels, Parts Code Numbers	
①	128377-07350
②	128296-07260
③	128296-07300
④	196630-12980

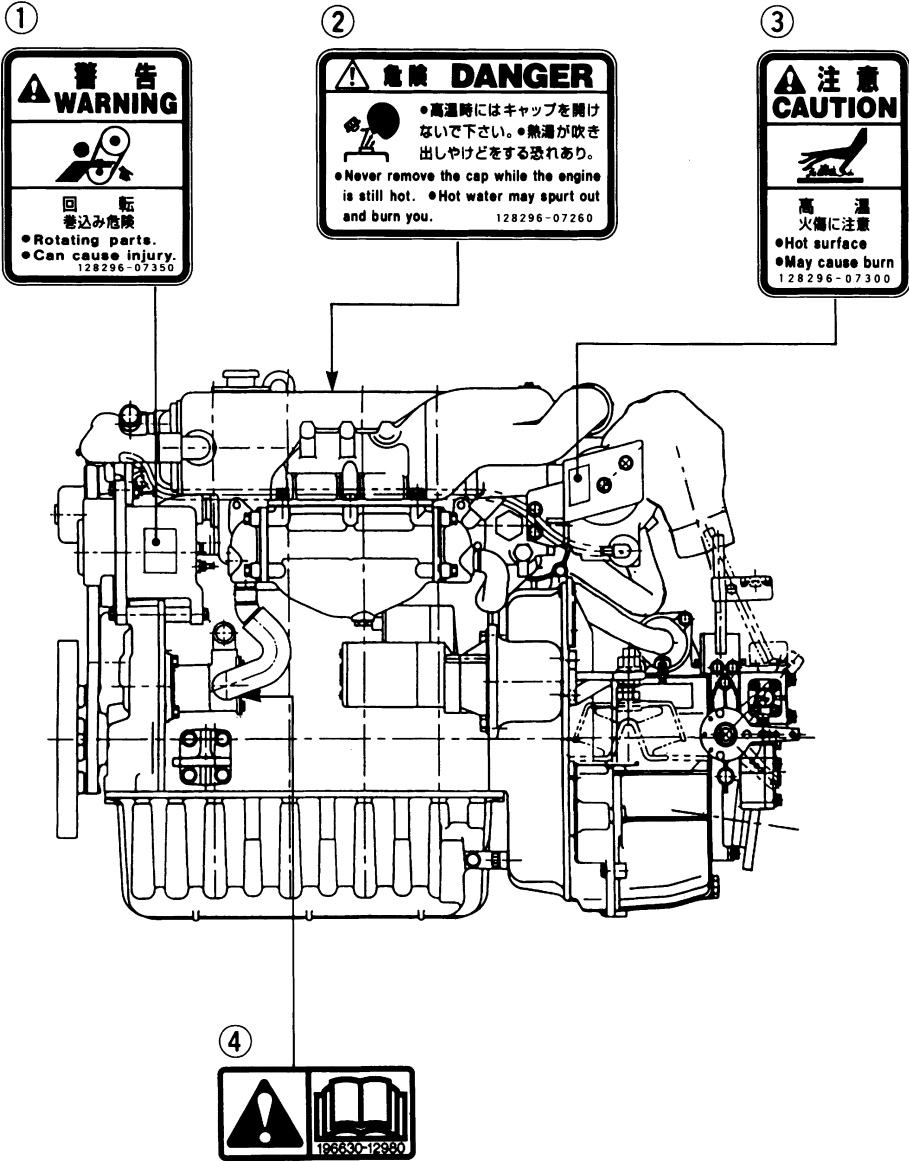

GB

## 2. Product explanation

### 2.1 USE, DRIVING SYSTEM, ETC.

This is a light, compact diesel engine for use in pleasure boats. The engine is equipped with a turbocharger and intercooler which insures maximum output while preserving lightness and compact size. (The 4JH3-TE series is equipped with the turbocharger only.)

Power output for this group of engines increases progressively from 4JH3-TE, 4JH3-HTE to 4JH3-DTE.

The inboard series is equipped with a marine gear connecting the output shaft with the propeller shaft for operation.

The different types of marine gears used for each series are shown below.

	Marine Gear	4JH3-TE Series	4JH3-HTE Series	4JH3-DTE Series
<b>KBW21 Clutch</b>	Mechanical wet cone clutch Input/output special parallel drive	4JH3-TE	4JH3-HTE	N/A
<b>KM4A Clutch</b>	Mechanical wet cone clutch 7° Down angle drive	4JH3-TBE	4JH3-HTBE	N/A
<b>KMH4A Clutch</b>	Hydraulic wet multiple disk clutch 8° Down angle drive	4JH3-THE	4JH3-HTHE	4JH3-DTHE

**GB**

In order to obtain full performance from your engine, it is imperative that you check the size and structure of the hull and use a propeller of the appropriate size.

The engine must be installed correctly with safe cooling water and exhaust piping and electrical wiring. The PTO work should be easy to use for onboard equipment.

The laws of some countries may require hull and engine inspections, depending on the use, size and cruising area of the boat.

The installation, fitting and surveying of this engine all require specialized knowledge and engineering skills. Consult Yanmar's local subsidiary in your region or your distributor or dealer.

Consult your Yanmar dealer or distributor when selecting optional parts. Optional parts selections should take into account operational and surrounding conditions.

This Operation Manual explains the basic points for standard operation. Variations are explained under the specially marked sections.

## 2. Product explanation

This Operation Manual explains the basic points for standard operation. Variations are explained under the letter emblems for easy reference.

**Model** : Explanation of indicated model only.

**Option** : Explanation of optional parts.

**Customer** : Explanation of use of parts from other boat manufacturers.

In sections without letter emblems, the explanation applies to all models.

Explanation for driving devices, propellers, etc. and optional parts are not included, and special attention should be paid to the explanations and safety precautions in the operation manuals provided by the boat and equipment manufacturers.

## 2. Product explanation

### 2.2 Engine Specifications

#### 2.2.1

Item		Unit	Model								
Engine Model		--	4JH3-TE		4JH3-TBE		4JH3-THE		4JH3-TCE		
Type		--	vertical 4-cycle water cooled diesel engine								
Combustion system		--	direct injection								
Number of cylinders		--	4								
Bore x stroke		mm	84 x 90								
Displacement		ℓ	1.995								
Aspiration system		--	turbocharger								
Continuous rating output	Output/crankshaft speed	kW/rpm (hp/rpm)	50.7 / 3700 (69 / 3700)								
	One hour rating output	kW/rpm (hp/rpm)	55.2 / 3800 (75 / 3800)								
Low idling		rpm	700 ± 25								
Fuel injection timing (b.T.D.C.)		°	12 ± 1								
Fuel injection pressure		kg/cm <sup>2</sup>	220 ± 5								
Main power take off			at flywheel side								
Front power take off			at crankshaft V-pulley side								
Direction of rotation	Crankshaft		Counter-clockwise viewed from stern								
	Propeller shaft (ahead)		clockwise	bi-rotation				counter-clockwise or clockwise viewed from stern			
Cooling system			fresh water cooler with heat exchanger								
Lubrication system			complete enclosed forced lubrication								
Starting system	Type		electric								
	Starting motor		DC 12V, 1.4 kW								
	AC generator		12V, 55A (12V, 80A optional)								
Engine	Lubricating oil capacity (rake angle)	standard unit ℓ	6.3 (7°)		7.05 (0°)						
	Marine gear	Model	KWB21		KM4A		KMH4A		SD40-4TSail Drive		
Type		mechanical wet multiple disk clutch Input/output eccentric parallel drive		mechanical wet cone clutch 7° down angle drive		hydraulic wet multiple disk clutch 8° down angle drive		Cone clutch			
Reduction ratio		Forward	2.17	2.62	1.47	2.14	2.63	3.30	2.04	2.45	2.32
		Reverse	3.06	3.06	1.47	2.14	2.63	3.30	2.04	2.45	2.32
Lubricating oil capacity	Total	ℓ	1.2		1.3		2.0		1.8		
Dimensions	L x W x H	mm	906 x 560 x 635		888 x 565 x 635		938 x 565 x 635		1086 x 565 x 433		
Cooling water capacity	Fresh water tank	ℓ	6.0								
	Subtank	ℓ	0.8								
Engine weight with marine gear		kg	249		247		250		260		

GB

1.) Rating condition: ISO 3046-1 and ISO 8665      2.) 1hp=0.7355 kW

## 2. Product explanation

### 2.2.2

Item		Unit	Model								
Engine Model		--	4JH3-HTE		4JH3-HTBE			4JH3-HTHE			
Type		--	vertical 4-cycle water cooled diesel engine								
Combustion system		--	direct injection								
Number of cylinders		--	4								
Bore x stroke		mm	84 x 90								
Displacement		ℓ	1.995								
Aspiration system		--	turbocharger, intercooler								
Continuous rating output	Output/crankshaft speed	kW/rpm (hp/rpm)	67.7 / 3700 (92 / 3700)								
One hour rating output	Output/crankshaft speed	kW/rpm (hp/rpm)	73.6 / 3800 (100 / 3800)								
Low idling		rpm	700 ± 25								
Fuel injection timing (b.T.D.C.)		°	12 ± 1								
Fuel injection pressure		kg/cm <sup>2</sup>	220 ± 5								
Main power take off			at flywheel side								
Front power take off			at crankshaft V-pulley side								
Direction of rotation	Crankshaft		Counter-clockwise viewed from stern								
	Propeller shaft (ahead)		clockwise	bi-rotation							
Cooling system			fresh water cooler with heat exchanger								
Lubrication system			complete enclosed forced lubrication								
Starting system	Type		electric								
	Starting motor		DC 12V, 1.4 kW								
	AC generator		12V, 55A (12V, 80A optional)								
Engine	Lubricating oil capacity (rake angle)	standard unit ℓ	6.3 (7°)		7.5 (0°)						
Marine gear	Model		KWB21		KM4A			KMH4A			
	Type		mechanical wet multiple disk clutch Input/output eccentric parallel drive		mechanical wet cone clutch 7° down angle drive			hydraulic wet multiple disk clutch 8° down angle drive			
	Reduction ratio		Forward	2.17	2.62	1.47	2.14	2.63	3.30	2.04	2.45
			Reverse	3.06	3.06	1.47	2.14	2.63	3.30	2.04	2.45
Lubricating oil capacity		Total	ℓ	1.2		1.3			2.0		
Dimensions	L x W x H		mm	906 x 576 x 660		888 x 581 x 660			938 x 581 x 660		
Cooling water capacity	Fresh water tank		ℓ	7.2							
	Subtank		ℓ	0.8							
Engine weight with marine gear		kg	258		256			259			

1.) Rating condition: ISO 3046-1 and ISO 8665      2.) 1hp=0.7355 kW

GB

## 2. Product explanation

### 2.2.3

Item		Unit	Model		
Engine Model		--	<b>4JH3-DTHE</b>		
Type		--	vertical 4-cycle water cooled diesel engine		
Combustion system		--	direct injection		
Number of cylinders		--	4		
Bore x stroke		mm	84 x 90		
Displacement		ℓ	1.995		
Aspiration system		--	turbocharger, intercooler		
Continuous rating output	Output/crankshaft speed	kW/rpm (hp/rpm)	85.3 / 3700 (116.0 / 3700)		
One hour rating output	Output/crankshaft speed	kW/rpm (hp/rpm)	91.9 / 3800 (125 / 3800)		
Low idling		rpm	700 ± 25		
Fuel injection timing (b.T.D.C.)		°	12 ± 1		
Fuel injection pressure		kg/cm <sup>2</sup>	220 ± 5		
Main power take off			at flywheel side		
Front power take off			at crankshaft V-pulley side		
Direction of rotation	Crankshaft		clockwise viewed from stern		
	Propeller shaft (ahead)		bi-rotation		
Cooling system			fresh water cooler with heat exchanger		
Lubrication system			complete enclosed forced lubrication		
Starting system	Type		electric		
	Starting motor		DC 12V, 1.4 kW		
	AC generator		12V, 55A (12V, 80A optional)		
Engine	Lubricating oil capacity (rake angle)	standard unit ℓ	7.5 (0°)		
Marine gear	Model		KMH4A		
	Type		hydraulic wet multiple disk clutch 8° down angle drive		
	Reduction ratio	Forward		2.04	2.45
		Reverse		2.04	2.45
	Lubricating oil capacity	Total	ℓ	2.0	
Dimensions	L x W x H	mm	938 x 581 x 660		
Cooling water capacity	Fresh water tank	ℓ	7.2		
	Subtank	ℓ	0.8		
Engine weight with marine gear		kg	260		

1.) Rating condition: ISO 3046-1 and ISO 8665

2.) 1hp=0.7355 kW

GB

## 2. Product explanation

### 2.3 Names of Parts

### Operation Side

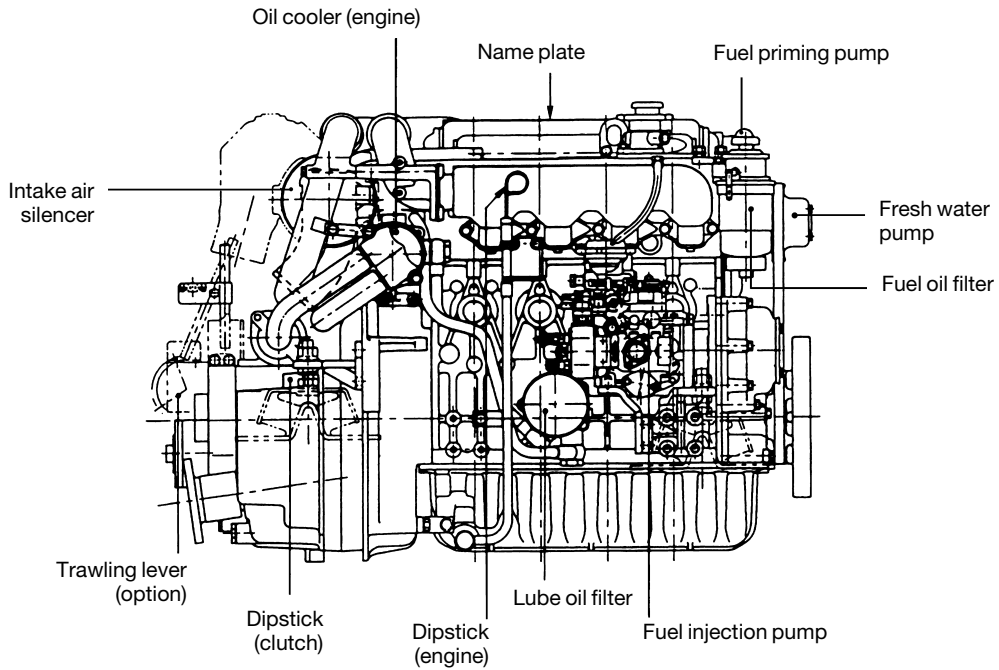

GB

### Non Operation Side

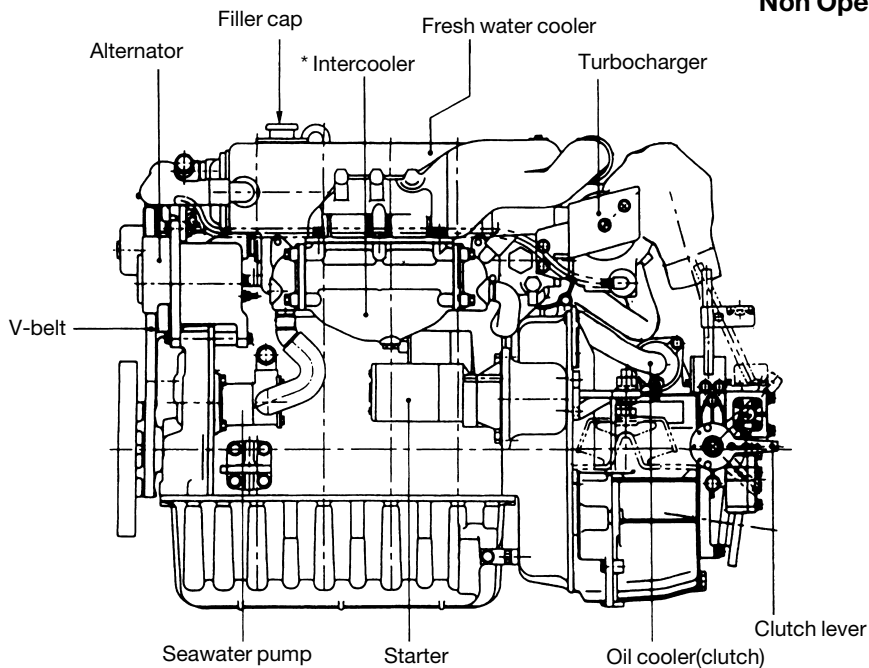

**NOTE:**

The 4JH3-DTHE engine (with KM44 clutch) is used as the example for the above diagram.  
 The 4JH3-TE Series is not equipped with an intercooler (indicated by \* in the diagram).

## 2. Product explanation

### 2.4 Major Servicing Parts

Name of part	Function
<b>Fuel filter</b>	Removes dust and water from fuel. The internal element (filter) should be changed periodically. A water separator is on the bottom of the filter and should be drained periodically.
<b>Fuel priming pump</b>	This is a manual fuel pump. Moving the knob on the top of the fuel filter feeds the fuel. The pump is also used to bleed air from the fuel system.
<b>Fuel feed pump</b>	This is a mechanical pump used to feed fuel to the fuel injection pump. It is built into the fuel injection pump.
<b>Filler port (engine)</b>	Filler port for engine lube oil.
<b>Filler port (marine gear)</b>	Filler port for marine gear lube oil.
<b>Dipstick (Lube oil)</b>	Gauge stick for determining the level of the engine and marine gear oil.
<b>Lube oil filter</b>	Filters fine metal fragments and carbon from the lube oil. Filtered lube oil is distributed to the engine's moving parts.
<b>Cooling System</b>	Seawater passes through the heat exchanger cooling the fresh water, which in turn cools the engine.
<b>Fresh water cooling</b> <i>Fresh water pump</i>  <i>Fresh water cooling</i>	There are two cooling systems: fresh water and seawater. The fresh water pump is run by the alternator and the V-belt.  The fresh water in the fresh water cooler is fed to the engine by the fresh water pump. The cooling fresh water returns to the engine after it is cooled with seawater in the fresh water cooler.
<b>Filler cap</b>	The filler cap on the cooling water tank covers the water supply port. The cap has a pressure regulating valve. When the cooling water temp. rises, the pressure rises inside the fresh water cooler.
<b>Subtank</b>	The pressure regulating valve releases vapor and hot water overflow to the subtank.
<b>Oil cooler (engine oil)</b>	This heat exchanger cools high temp. engine oil with seawater.
<b>Oil cooler (clutch oil)</b>	This heat exchanger cools high temp. clutch oil with seawater.
<b>Turbocharger</b>	With the pressurized intake air feeding device the exhaust gas turbine is rotated by exhaust gas, and the power is used to rotate the blower. This pressurizes the intake air for sending to the cylinder gives high power output.
<b>Intercooler</b>	This heat exchanger cools the pressurized intake air from the turbocharger with seawater and further compresses it.
<b>Intake air silencer</b>	This is the air intake silencer. The silencer guards against dirt in the air and reduces the noise of air intake.
<b>Name plate</b>	Name plates are provided on the engine and the marine gear and have the model, serial number and other data.
<b>Starter</b>	Starter motor for the engine. Powered by the battery.
<b>Alternator</b>	Rotates by belt drive, generates electricity and charges the battery.

GB



## 2. Product explanation

### 2.5 Control Equipment

#### 2.5.1 Control Panel

The instrument panel is located in the control room. The following instruments enable you to start/stop the engine and to monitor its condition during operation.

#### B type

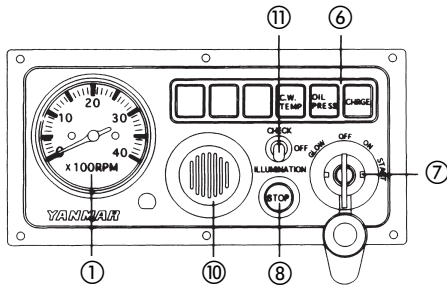

#### New B type

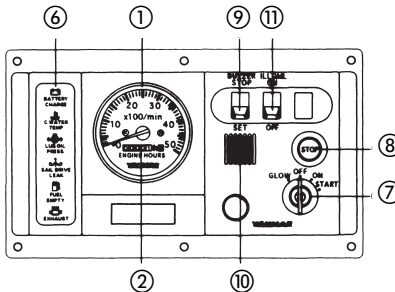

#### C type

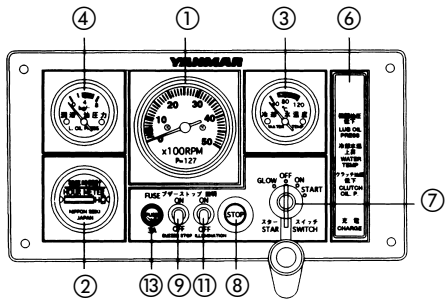

#### New C type

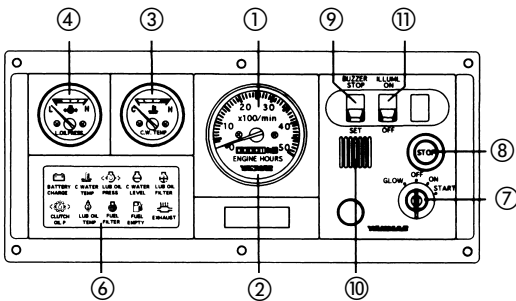

GB

#### D type

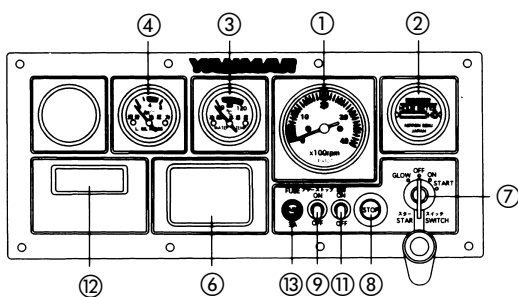

#### New D type

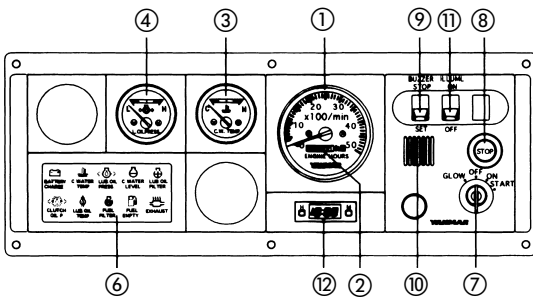

- ① Tachometre
- ② Hour metre
- ③ C.W. temp. metre
- ④ L.O. temp. metre
- ⑤ Boost pressure metre

- ⑥ Alarm lamps
- ⑦ Starter switch
- ⑧ Stop button switch
- ⑨ Buzzer stop switch
- ⑩ Alarm buzzer

- ⑪ Illumination switch
- ⑫ Digital clock
- ⑬ Fuse

## 2. Product explanation

### (1) Metres

The following metres are located in the upper centre part of the instrument panel.

- B/C/D and New B/C/D type panels use analog electric systems and have a pointer indicator.

Turn the panel light switch ON for easy viewing.

- Tachometre  
The engine's rotation speed is indicated. Load and engine rotation can be monitored.
- Hour metre  
The number of hours of operation is indicated, and can be used as a guide for periodic maintenance checks.
- Cooling Water Temperature Metre  
**Option Instrument Panel C.D.**  
The cooling water temperature is indicated. Enables monitoring of the cooling condition of the engine.
- Lube Oil Pressure Metre  
**Option Instrument Panel C.D.**  
The engine oil pressure is indicated. Enables monitoring of the condition of the engine's lube oil.

insufficient oil will result in damage and seizure. Check the oil level.

### 4 FUEL FILTER



When the drain inside the water separator in the fuel filter becomes excessive, the sensor will cause the lamp to come on. Clean out the drain in the water separator. If operation is continued without cleaning, it will become impossible to feed fuel to the engine or damage and seizure of the fuel injection pump will result.

### 5 EXHAUST **Option**



When the amount of cooling seawater being discharged becomes too small, the sensor will activate the lamp. Continuing operation under this condition will result in damage and seizure. Check for clogging in the seawater cooling system and damaged parts.

GB

### 1 BATTERY CHARGE



When the charge is abnormal, the lamp will come on. When charging begins the lamp will go off. (Alarm buzzer will not sound when the lamp comes on.)

### 2 C. WATER TEMP



When the temperature of the cooling fresh water exceeds the maximum (95°C or higher), the lamp will light. Continuing operation at temperatures exceeding the maximum will result in damage and seizure. Check the load and the fresh water cooling system for any abnormalities.

### 3 LUB. OIL PRESS.



When the lube oil pressure falls below normal the oil pressure sensor will register this and the lamp will come on. Continuing operation with

## 2. Product explanation

### (2) Controls and Equipment

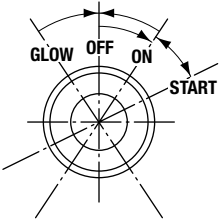
Controls and Equipment	Mechanism			
	<p><b>Key Switch</b>                      Rotary switch with 4 positions.                      In the OFF position, the switch key can be inserted or removed.                      In OFF, all electric current is cut off.                      In ON (1 position to the right), the engine is turned on.                      In ON, electric current to the controls and equipment is turned on.                      In the START position the engine will start.                      The engine cannot be stopped with the key switch.                      In GLOW, position for turning on the air heater.                      The air heater <b>Option</b> aids starting during cold conditions by warming up the intake air before starting.</p>			
<table border="1" style="width: 100%; border-collapse: collapse;"> <tr><td style="background-color: black; color: white; padding: 2px;"><b>Option</b></td></tr> <tr><td style="background-color: black; color: white; padding: 2px;"><b>KM4A Clutch</b></td></tr> <tr><td style="background-color: black; color: white; padding: 2px;"><b>KMH4A Clutch</b></td></tr> </table>	<b>Option</b>	<b>KM4A Clutch</b>	<b>KMH4A Clutch</b>	<p><b>Note:</b>  <b>Neutral Safety Switch</b>                      The engine can only be started when the clutch is in neutral. If an attempt is made to start the engine in any other position, the neutral safety switch will operate to make starting impossible.</p>
<b>Option</b>				
<b>KM4A Clutch</b>				
<b>KMH4A Clutch</b>				

GB

### (3) Alarm Equipment (lamps and buzzer)

**Mechanism**

When the sensor detects a problem during operation, the lamps come on and the buzzer goes off.

Alarm monitors are located on the control panel. Under normal conditions, the monitors are off. When there is a problem, the monitors light up.

### (4) Alarm Devices

Check that the pilot lamps on the instrument panel are as shown below when the starter key is turned on:

Pilot lamps	Low L.O. pressure alarm lamp	Lit
	Charge lamp	Lit
	Cooling water temp. alarm lamp	Off

**NOTE:**  
*All these signals will continue until the engine starts up or the key is turned off.*

## 2. Product explanation

### 2.5.2 Remote Control Handle

#### (1) Morse Type **Option**

This remote control system uses a single handle to operate marine gear-clutch- (neutral, forward, reverse) and to control the engine speed.

NEUTRAL: Power to the propeller shaft is cut off and the engine idles.

FWD (FORWARD)

REV (REVERSE)

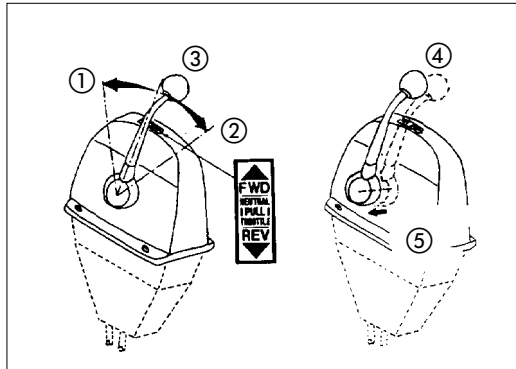

- ① FWD (forward)
- ② REV (reverse)
- ③ NEUTRAL (boat is stopped)
- ④ Clutch is disengaged
- ⑤ Pull out handle

The handle controls the course of the boat (ahead or astern) and, at the same time, acts as an accelerator increasing the engine speed as it is pushed further in the FWD or REV direction. If the handle is pulled out, engine speed can be controlled without engaging the clutch (clutch remains in the NEUTRAL, no load position).

### **NOTICE**

**Yanmar recommends the use of a single-lever type for the remote control lever. If only the two-lever type is available in the market, operate the engine at 1000 rpm or lower before engaging and disengaging the marine gear-clutch.**

#### (2) Trawling Handle **Option KMH4A Clutch**

(The trawling valve is optional to KMH4A Clutch only.)

The trawling control is a single remote control handle.

The marine gear trawling lever operates by remote control cable.

The operation labels on the handle are :

H : High speed (normal operation)

L : Low speed (trawling operation)

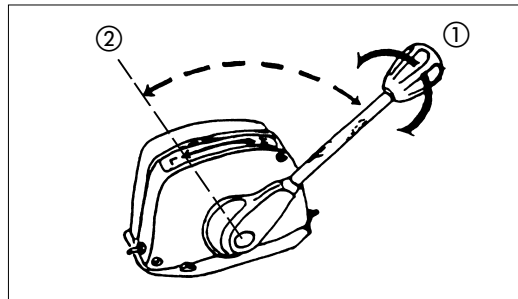

- ① H (High speed)
- ② L (Low Speed)

Only operate with the trawling handle in the low speed position, 1000 rpm or less.

In L (low speed) the clutch is at half clutching position and the propeller turns very slowly rubbing against the friction plate.

The engine cannot be run at high speed under these conditions.

1. Loosen the handle grip by turning it to the left.
2. Move the handle toward L and position at the desired speed.

## 2. Product explanation

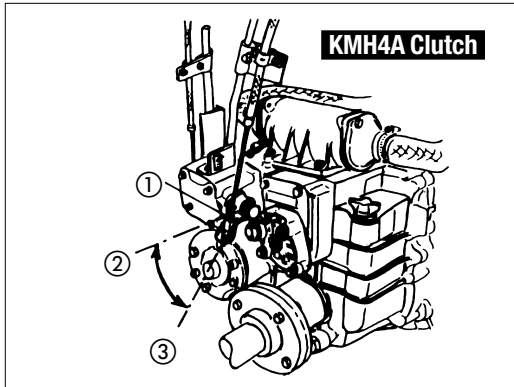

- ① Trawling lever
- ② High speed
- ③ Low speed (trawling)

### **NOTICE**

**Before returning to normal high speed operation, be sure to position the handle in H.**

### 2.5.3 Stopping Equipment

#### Electric Operation

Push the stop button on the instrument panel. Continue to push the stop button until the engine has come to a complete stop.

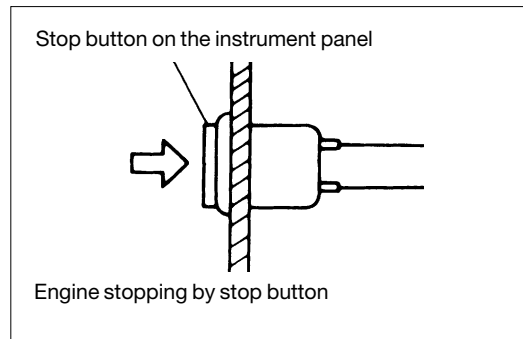

### **CAUTION**

**If the engine is stopped suddenly at a high temperature, the temperature of various parts will increase and engine trouble may occur.**

**GB**

## 3. Operation

### 3.1 Fuel Oil, Lube Oil, and Cooling Water

#### 3.1.1 Fuel Oil

#### **NOTICE**

**When other than the specified fuel oil is used, the engine will not perform to full capacity and parts may be damaged.**

#### (1) Selection of Fuel Oil

Use diesel fuels only.  
Cetane fuel number should be 45 or greater.

#### (2) Handling of Fuel Oil

- 1) Water and dust in the fuel cause engine failure. When fuel is stored, be sure that the inside of the storage container is clean, and that the fuel is stored away from dirt or rain water.
- 2) Keep the fuel container stationery for several hours to allow any dirt or water to settle to the bottom. Use a pump to extract the clear, filtered fuel from the top of the container for use.

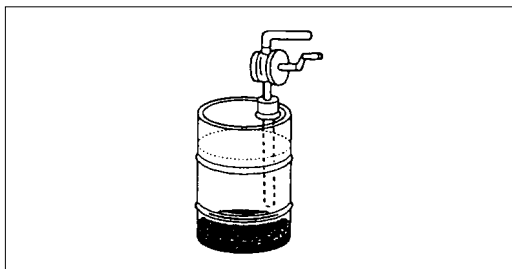

Use the clear filtered fuel from the upper middle section of the container only, leaving any contaminated fuel at the bottom.

#### (3) Fuel System

Install the fuel pipe from the fuel tank to the fuel pump in accordance with the diagram.

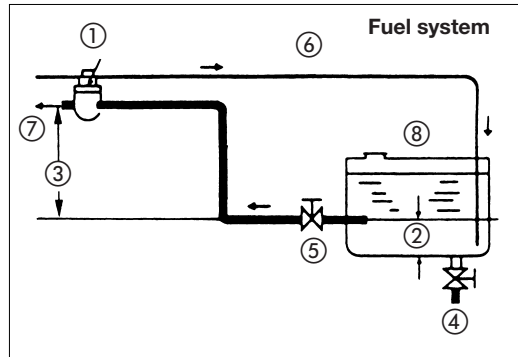

- |                    |                          |
|--------------------|--------------------------|
| ① Fuel filter      | ⑥ Fuel return            |
| ② Approx. 20~30 mm | ⑦ To fuel injection pump |
| ③ Within 500 mm    | ⑧ Fuel tank              |
| ④ Drain cock       |                          |
| ⑤ Fuel cock        |                          |

#### 3.1.2 Lube Oil

#### **NOTICE**

**Using other than the specified lube oil will lead to seizure of parts, abnormal wear, and shorten engine life.**

#### (1) Selection of Engine Lube Oil

Use the following lube oil:

- API Classification.....CD
- SAE Viscosity .....15W40

#### (2) Clutch Oil Selection

Use the following lube oil:

- 4JH3-TE, 4JH3-HTE Series Converter oil for automobiles ATF-A
- **KBW21 Clutch**
- 4JH3-TBE, 4JH3-HTBE, 4JH3-DTBE Series and 4JH3-THE, 4JH3-HTHE, 4JH3-DTHE Series
- **KM4A Clutch** **KMH4A Clutch**

API Classification..... CC or higher  
SAE Viscosity..... #20 or #30

GB

## 3. Operation

### (3) Handling the Lube Oil

- 1) When handling and storing lube oil, be careful not to allow dust and water to enter the lube oil. Clean around the filter port before refilling.
- 2) Do not mix lube oils of different types or brands. Mixing may cause the chemical characteristics of the lube oil to change and lubricating performance to drop, reducing the engine's life. Before supplying lube oil to the engine and marine gear for the first time, extract all the lube oil already in the tank. Use new lube oil.
- 3) Lube oil supplied to the engine will undergo natural degeneration with time even when the engine is not used. Lube oil should be replaced at the specified intervals, regardless of whether the engine is being used or not.

### 3.1.3 Cooling Water

It is important to check the cooling water daily. Be sure to use clean soft water (tap water) for cooling fresh water.

#### **NOTICE**

**Be sure to add antirust or antifreeze to cooling fresh water. In cold seasons, the antifreeze is especially important. Without antirust, cooling performance will drop due to scale and rust in the cooling water system. Without antifreeze, cooling water will freeze and expand, breaking various parts. For your reference, antifreeze mixed with antirust is now available in the market.**

### Handling of Cooling Water

1. Choose antirust which will not have any adverse effects on the materials (cast iron, aluminum, copper, etc.) of the engine's fresh water cooling system.
2. Use the proper mixing ratio of antirust to fresh water strictly as instructed by the antirust maker.
3. Replace the cooling water periodically, according to the maintenance schedule given in this operation manual.
4. Remove the scale from the cooling water system periodically, according to the instructions in this operation manual.
5. Use the proper mixing ratio of antifreeze to fresh water strictly, as instructed by the antifreeze maker. If too much antifreeze is used, the cooling performance of the cooling water will drop and the engine may become overheated.
6. Do not mix different brands of antirust or antifreeze. Chemical reactions may make the antifreeze or antirust useless and engine trouble could result.

#### **NOTICE**

**Excessive use of antifreeze also lowers the cooling efficiency of the engine. Be sure to use the mixing ratios specified by the antifreeze maker for your temperature range.**

**GB**

## 3. Operation

### 3.2 Before Initial Operation

Perform the following before using the engine for the first time:

#### 3.2.1 Supply Fuel Oil

**⚠ DANGER**



**Using gasoline, etc. may cause a fire.**

**To avoid mistakes, be sure to double-check the kind of fuel before inserting. Wipe off any spilled fuel carefully.**

1. Before filling with fuel, wash out the fuel tank and fuel system with clean kerosene or light oil.
2. Fill the tank with clean fuel oil free of dirt and water.

**GB**

#### 3.2.2 Bleeding the Fuel System

Bleed the fuel system according to the following procedure. When there is air in the fuel system, the fuel injection pump will not be able to function.

1. Open the fuel cock of the fuel tank.
2. Loosen the air bleeding bolt on the top of the fuel filter by turning it 2~3 times.

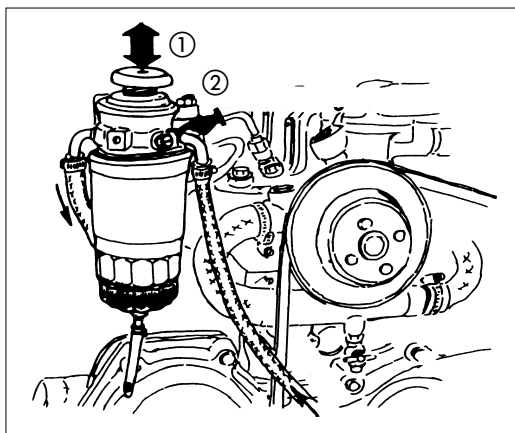

① Priming pump    ② Air bleeding bolt

3. Move the priming pump knob up and down until fuel mixed with air bubbles flows out of the air bleeding bolt and tighten the air bleeding bolt. The priming pump is on the top of the fuel filter.

#### 3.2.3 Supply Engine Lube Oil

1. Remove the filler port cap (yellow) at the top of the bonnet, and fill with engine oil.
2. Fill with oil to the upper limit on the dipstick. Insert the dipstick fully to check the level.  
Engine oil capacity: *See 2.2 Engine Specifications*
3. Tighten the filler port cap securely by hand.

**NOTICE**

**Do not overfill.**

**Overfilling will cause oil to be sprayed out from breather and lead to engine problems.**

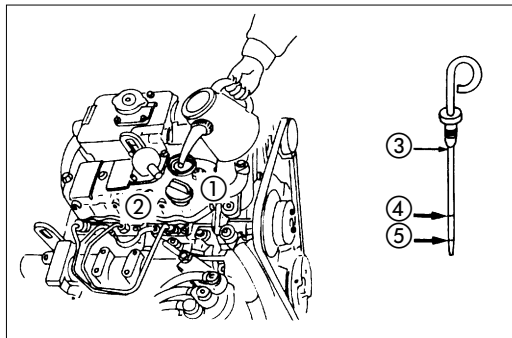

① Filler port    ③ Dipstick    ⑤ Lower limit  
② Bonnet    ④ Upper limit



## 3. Operation

### 3.2.4 Supply Clutch Lube Oil

1. Remove the filler port cap at the top of the bonnet, and fill with marine gear-clutch- lube oil.
2. Fill with oil to the upper limit on the dipstick. Insert the dipstick fully to check the level.

Clutch oil capacity: *See 2.2 Engine Specifications*

3. Tighten the filler port cap securely by hand.

#### NOTICE

**Do not overfill. Overfilling will cause oil to be sprayed out during operation and affect the efficiency of the marine gear.**

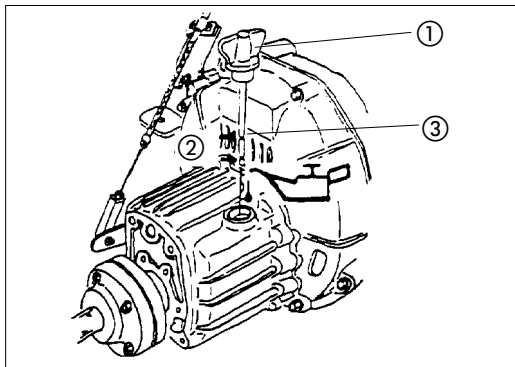

- ① Oil filler port cap      ③ Dipstick  
② Upper limit/Lower limit

### 3.2.5 Supply Cooling Water

Supply cooling water according to the following procedures. Be sure to add antirust or antifreeze to the cooling water.

1. Be sure to close the water drain cocks.

*Note:* The water drain cocks are opened before shipping from the plant.

#### 4JH3-TE series KMH4A Clutch

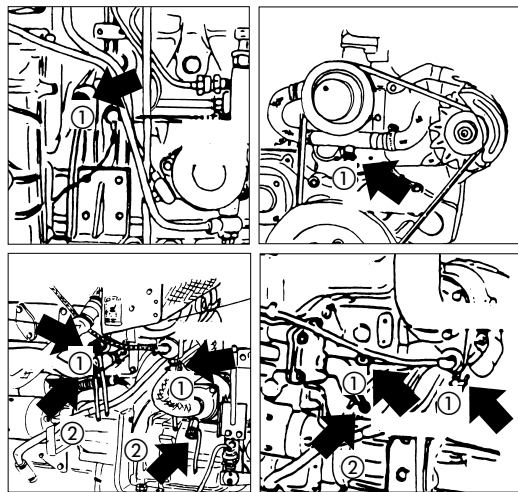

- ① Fresh water      ② Seawater

2. Remove the filler cap of the fresh water cooler by turning the cap counterclockwise 1/3 of a turn.

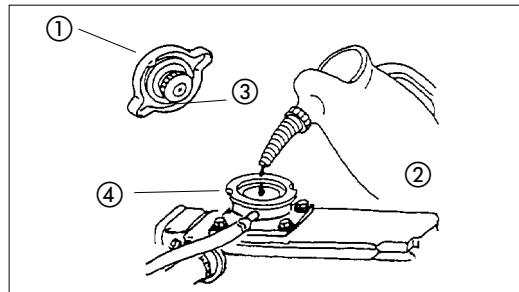

- ① Filler cap      ② Fresh water cooler  
③ Dents      ④ Notches

GB

### 3. Operation

- Pour cooling water slowly into the fresh water tank so that air bubbles do not develop. Supply until the water overflows from the filler port.  
Fresh water tank capacity: See 2.2 *Engine Specifications*

**▲ DANGER** **If the filler cap is loose, hot steam and water will spout out which may cause burns.**



- After supplying cooling water, replace filler cap and tighten it firmly. Failure to do so will cause water leakage. To replace the cap, align the detents on the bottom of the cap with the notches on the filler port and turn clockwise  $\frac{1}{3}$  of a turn.

**GB**

- Remove the subtank cap and fill with water to the lower limit.  
Replace cap.  
Subtank capacity: 0.8 l
- Check the rubber hose connecting the subtank to the fresh water cooler. Be sure the hose is securely connected and there is no looseness or damage. When the hose is not watertight, an excessive amount of cooling water will be used.

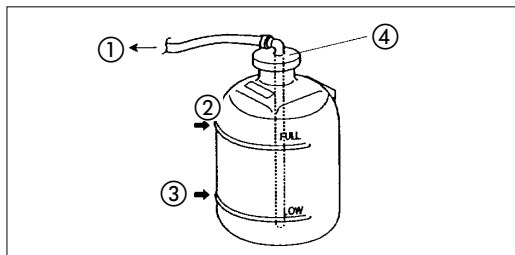

① To fresh water cooler      ② Upper limit  
③ Lower limit                  ④ Cap

#### 3.2.6 Cranking

When the engine is being used for the first time or has not been used for a long period of time, lube oil will not be distributed to all of the operating parts. Using the engine in this condition will lead to seizure.

After a long period of disuse, distribute lube oil to each part by cranking. Perform in accordance with the following procedures before beginning operation.

- Open Kingston cock.
- Open fuel tank cock.
- Put remote control lever in NEUTRAL.

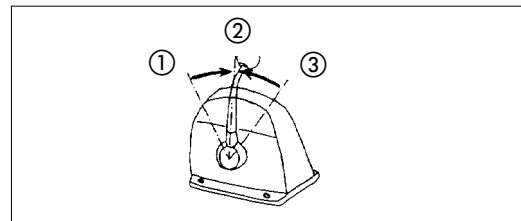

① Forward      ② Neutral      ③ Reverse

- Turn on battery switch and insert key into key switch. Turn the key to the ON position.
- Electric stop device**  
Push the stop button on the instrument panel continuously while cranking.
- When the key switch is turned, the engine will begin cranking. Continue cranking for about 5 seconds, and check for abnormal noise during that time. (If you remove your hand from the stop knob or stop button while cranking, the engine will start.)

## 3. Operation

### 3.2.7 Check and Resupply Lube Oil and Cooling Water

When engine oil, clutch oil, or cooling water is supplied for the first time or when they must be replaced, conduct a trial operation of the engine for about 5 minutes and check the quantity of lube oil and cooling water. The trial engine operation will send the lube oil and cooling water to the parts, so the lube oil and cooling water levels will drop. Check and resupply as necessary.

1. Supplying engine lube oil (See 3.2.3)
2. Supplying marine gear lube oil (See 3.2.4)
3. Supplying cooling water (See 3.2.5)

### 3.3 Operating your engine

#### WARNING



Alcohol



Exhaust gas



Moving parts



Burns

#### 3.3.1 Inspection Before Starting

Before starting the engine, make it a daily rule to conduct the following inspections:

#### (1) Visual Checks

Check for the following:

1. Lube oil leakage from the engine
2. Fuel oil leakage from the fuel system
3. Water leakage from the cooling water system
4. Damage to parts
5. Loosening or loss of bolts

If any problem is found, do not operate the engine before completing repairs.

#### (2) Checking and Resupplying Fuel Oil

Check the fuel level inside the fuel tank and supply with the recommended fuel, if necessary. (See 3.2.1)

#### (3) Checking and Resupplying Engine Lube Oil

1. Check the engine oil level with the oil dipstick.
2. If the oil level is low, supply with the recommended lube oil using the filler port. Supply oil up to the top mark on the oil dipstick. (See 3.2.3)

#### (4) Checking and Resupplying Clutch Lube Oil

1. Check the clutch oil level with the oil dipstick.
2. If the oil level is low, supply with the recommended lube oil using the filler port. Supply oil up to the top mark on the oil dipstick. (See 3.2.4)

#### (5) Checking and Resupplying Fresh Water (For Fresh Water Cooling System)

Check the fresh water level before operation while the engine is cold.

Checking the water level while the engine is hot is dangerous, and the cooling water reading will be misleading due to thermal expansion.

Check and supply cooling water routinely at the subtank only.

Do not remove the filler cap of the fresh water tank during usual operation.

GB

## 3. Operation

### **▲ DANGER**



**If the filler cap is loose, hot steam and water will spout out which may cause burns.**

1. Check that the cooling fresh water level is above the lower limit on the side of the subtank.
2. If the water level is close to the lower limit, remove the subtank cap and supply fresh water.
3. When the water in the subtank runs out, remove the filler cap of the fresh water cooler and supply water until it overflows from the filler port. (See 3.2.5)

### **NOTICE**

**If the cooling fresh water runs out too often, or only the cooling fresh water in the fresh water tank drops without any change in the water level of the subtank, there may be some leakage of water or air. In such cases, consult your Yanmar dealer or distributor without delay.**

*Note:* The water rises in the subtank during engine operation.

This is not abnormal. After stopping the engine, the cooling water cools down and the extra water in the subtank returns to the fresh water tank.

### **(6) Checking the Remote Control Handle**

Be sure to check that the remote control handle lever moves smoothly before use. If it is hard to operate, lubricate the joints of the remote control cable and also the lever bearings.

If the lever comes out or there is play in the lever, adjust the remote control cable. (See 4.3.4 (5))

### **(7) Preparing Fuel, Lube Oil, and Cooling Fresh Water in Reserve**

Prepare sufficient fuel for the day's operation. Always store lube oil and cooling fresh water in reserve (for at least one refill) onboard, to be ready for emergencies.

### **(8) Checking the Alarm Devices Electric Operation**

When operating the key switch, check that the alarm devices work normally. (See 2.5.1 (4))

**GB**

## 3. Operation

### 3.3.2 How to Start the Engine

#### (1) Start the engine according to the following procedures:

##### Electric Operation

1. Open the Kingston cock.
2. Open the fuel tank cock.
3. Set the remote control lever in NEUTRAL.

#### **NOTICE**

Safety equipment **Option** makes it impossible to start the engine in any other position than NEUTRAL.

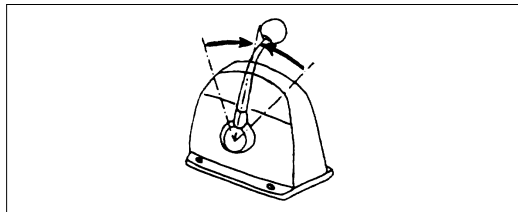

4. Turn on the battery switch.
5. Insert the key into the key switch and turn the key to ON. If the alarm buzzer sounds and alarm lamps come on, the alarm devices are normal.  
*Note:* The cooling water temp. warning lamp does not come on.  
(See 2.5.1.(4))
6. Turn the key switch to start the engine. Release the key switch when the engine has started. The alarm buzzer should stop and the alarm lamps go out.

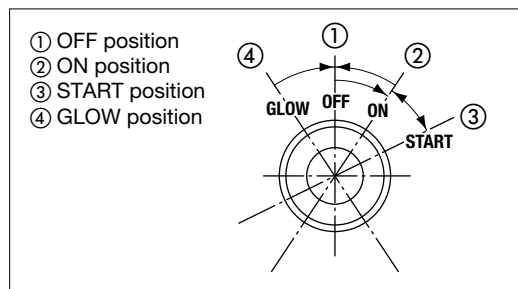

#### (2) Starting Under Low Temperature Conditions

When starting the engine under difficult low temperature conditions (approximately 0°C or lower), use the air heater to enable easier starting.

#### **NOTICE** **Option**

**Do not leave the air heater on for longer than 20 seconds at a time. Leaving the air heater on for longer periods of time will result in damage.**

Follow steps 1~4 of the above procedure, and then follow the steps below:

5. Turn the key from the OFF position to GLOW. Continue to hold the key in the GLOW position to allow the air heater to warm up the engine.
6. Turn the key to START and start the engine. After the engine starts, remove your hand from the key.

**GB**

#### (3) Restarting After Starting Failure

Before turning the key switch again, be sure to confirm that the engine has stopped completely. If the engine is restarted while the engine still has not stopped, the pinion gear of the starter motor will be damaged. When the engine will not start after several attempts, check the fuel system. If there is air in the fuel system, the fuel will not be fed and starting will not be possible. After bleeding air from the system, attempt to restart the engine. See 3.2.2

#### **NOTICE**

**Turn the key for a maximum of 15 seconds in the start position. If the engine does not start the first time, wait for about 1 minute before trying again.**

## 3. Operation

### (4) After the Engine has Started

After the engine has started, check the following items at a low engine speed:

1. Check that the gauges and alarm devices on the instrument panel are normal.
2. Check for water or oil leakage from the engine.
3. Check that exhaust colour, engine vibrations and sound are normal.
4. When there are no problems, keep the engine at low speed with the boat still stopped to send lube oil to all parts of the engine.
5. Check that sufficient cooling water is discharged from the seawater outlet pipe. Operation with too small seawater discharge will burn the impeller of the seawater pump. If seawater discharge is too small, stop the engine immediately. Identify the cause and repair.
  - Is the Kingston cock open?
  - Is the inlet of the Kingston cock on the hull bottom clogged?
  - Is the seawater suction hose broken, or does the hose suck in air due to a loose joint?

GB

### NOTICE

**The engine will seize if it is operated when cooling seawater discharge is too small or if load is applied without any warming up operation.**

### 3.3.3 Operation

#### (1) Engine Acceleration and Deceleration

Use the governor handle to control acceleration and deceleration. Move the handle slowly.

#### (2) FORWARD-NEUTRAL (boat stopped) – REVERSE Clutch

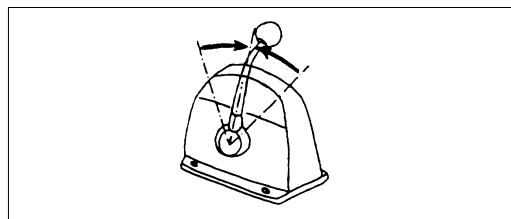

Use the clutch handle to change from FORWARD to NEUTRAL (boat stopped) to REVERSE.

### NOTICE

**Shifting the clutch while operating at high speed or not pushing the handle fully into position (half clutch) will result in damage to clutch parts and abnormal wear.**

1. Before using the clutch, be sure to move the governor handle to a low speed position (less than 1000 rpm). Move the governor handle to a high speed position after completing clutch operation.
2. When changing between FORWARD and REVERSE, bring the clutch to NEUTRAL and pause before slowly shifting to the desired position. Do not shift abruptly from FORWARD to REVERSE or vice versa.
3. Move the clutch handle accurately and fully into the FORWARD, NEUTRAL, and REVERSE positions.

## 3. Operation

### (3) Switching to Trawling

Use the trawling handle to begin trawling.

1. Operation continues at a low engine speed of 1000rpm or less.
2. Reduce the speed by moving the trawling handle from H to L.  
Adjust the speed to the desired rate and secure the trawling handle in place.
3. Before returning to normal operation, be sure to move the trawling handle from L to H.

#### **NOTICE**

**Option KMH4A Clutch**

When trawling, do not raise the engine speed above 1000rpm, as this results in early wear of and damage to the clutch.

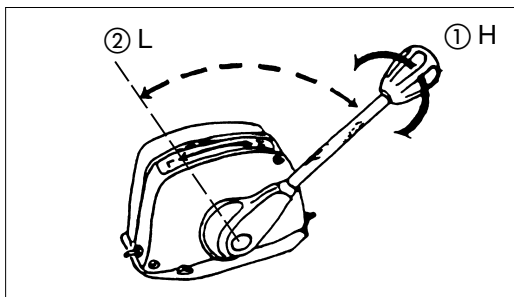

- ① High speed (normal operation)
- ② Low speed (trawling operation)

### 3.3.4 Cautions During Operation

Always be on the lookout for problems during engine operation.

Pay particular attention to the following:

#### **(1) Is sufficient water being discharged from the seawater outlet pipe?**

If the discharge is small, stop the engine immediately, identify the cause and repair.

#### **(2) Is the exhaust colour normal?**

The continuous emission of black exhaust indicates engine overloading. This shortens the engine's life and should be avoided.

#### **(3) Are there abnormal vibrations or noise?**

Depending on the hull structure, engine and hull resonance may suddenly become great at a certain engine speed range, causing heavy vibrations. Avoid operation in this speed range. If you hear any abnormal sounds, stop the engine and inspect.

#### **(4) Alarm buzzer sounds during operation.**

If the alarm buzzer sounds during operation, lower the engine speed immediately, check the warning lamps, and stop the engine for repairs.

#### **(5) Is there water, oil, or gas leakage, or are there any loose bolts?**

Check the engine room periodically for any problems.

#### **(6) Is there sufficient fuel oil in the fuel oil tank?**

Replenish fuel oil in advance to avoid running out of fuel during operation.

#### **7) When operating the engine at low speed for long periods of time, race the engine once every 2 hours.**

*Note:* Racing the Engine

With the clutch in NEUTRAL, accelerate from the low speed position to the high

**GB**

## 3. Operation

speed position and repeat this process about 5 times. This is done to clean out carbon from the cylinders and the fuel injection valve.

Neglecting to race the engine will result in poor exhaust colour and reduce engine performance.

### **NOTICE**

#### **Electric Operation**

**Never turn off the battery switch or spark the battery cable during operation. Damage to parts in the electric system will result.**

#### 3.3.5 Stopping the Engine

Stop the engine in accordance with the following procedures:

**GB**

1. Put the remote control handle in NEUTRAL.
2. Be sure to race the engine before stopping it. (See 3.3.4 (7))
3. Cool down the engine at low speed (approximately 1000 rpm) for about 5 minutes.

### **NOTICE**

**Stopping the engine suddenly while operating at high speed will cause the engine temperature to rise quickly, causing deterioration of the oil and sticking of parts.**

4. Push the stop button on the instrument panel.

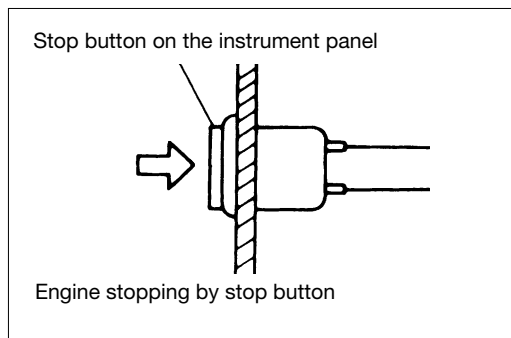

5. Turn the starter switch to OFF.
6. Close the fuel tank cock.
7. Close the Kingston cock.

### **NOTICE**

**Neglecting to close the Kingston cock will allow water to leak into the boat and may cause it to sink. Be sure to close the cock.**



# 3. Operation

## 3.3.6 Procedure

The following diagram shows the procedures for operation explained up to this point. Parts of the operation may differ depending on the remote control system being used. Accompanying operation manuals should be read carefully and understood.

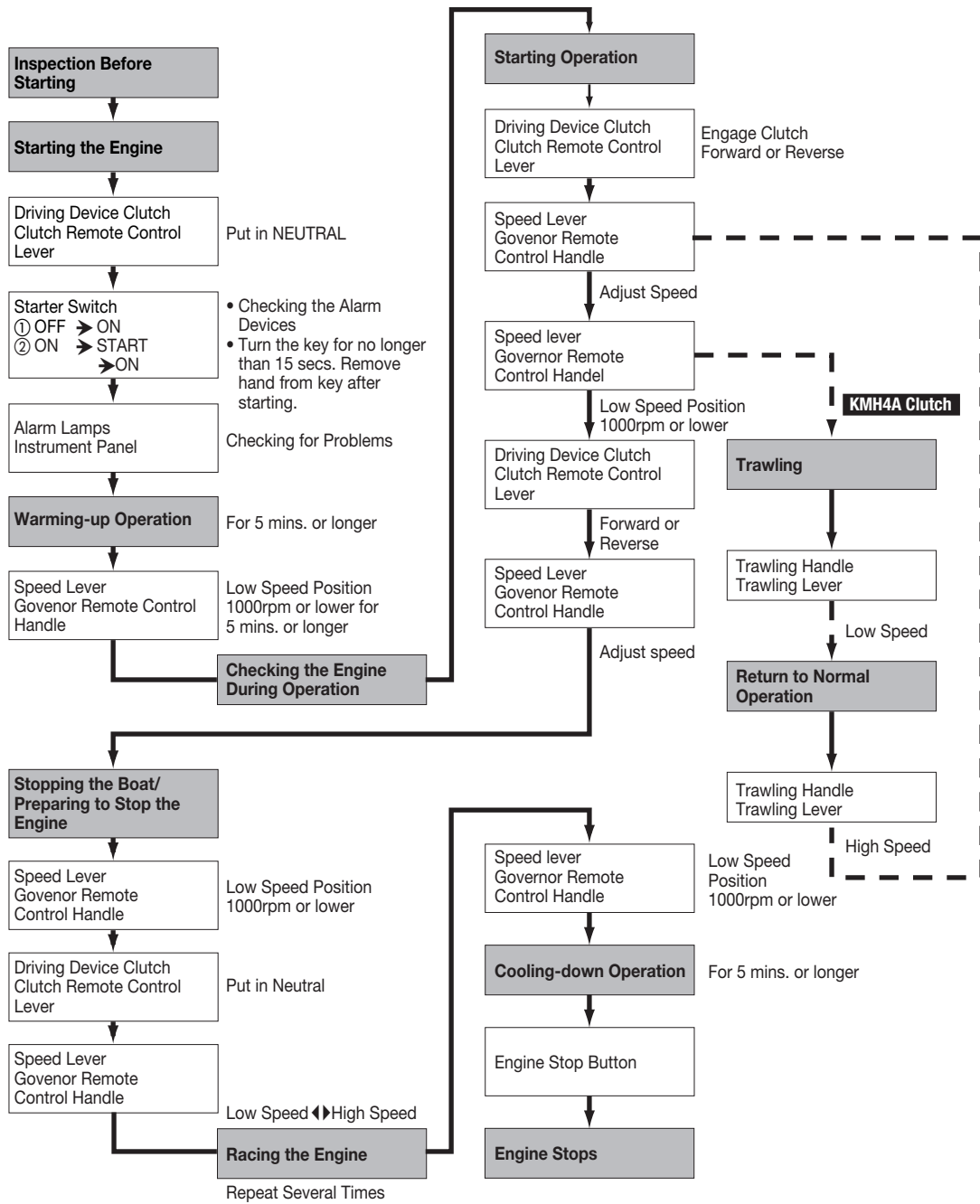

## 3. Operation

### 3.4 Long Term Storage

(1) In cold temperatures or before long term storage, be sure to drain the water from the seawater cooling system.

#### ⚠ CAUTION



Burns

### Seawater System

#### NOTICE

If water is left inside, it may freeze and damage parts of the cooling system (fresh water cooler, seawater pump, etc.) when ambient temperature is below 0°C.

2. Loosen the 4 bolts fixing the side cover of the seawater pump, remove the cover and drain the water from inside. Retighten the bolts when finished.
3. Close the drain cocks.

(2) If antifreeze has not been added to the cooling fresh water, be sure to drain off the water from the fresh water cooling system daily after use.

### Fresh Water Cooling

#### NOTICE

If the water is not removed, it may freeze and damage parts of the cooling water system (fresh water cooler, cylinder block, cylinder head, etc.) when ambient temperature is below 0°C.

1. Open the water drain cocks as illustrated and drain the cooling water.
2. Close the drain cocks after draining the water.

GB

#### 4JH3-TE Series

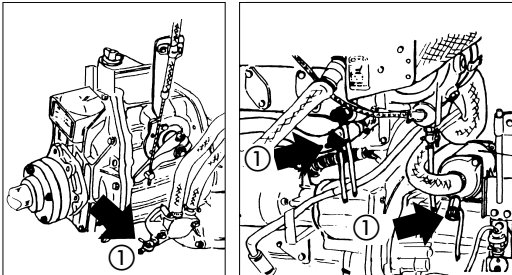

#### 4JH3-HTE/DTE Series

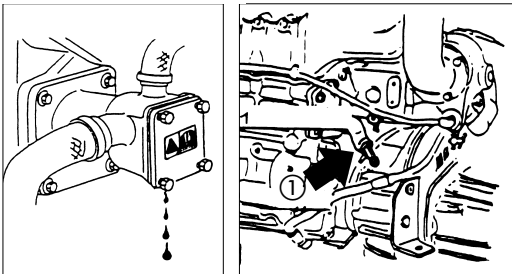

① Seawater

1. Loosen the drain cocks as illustrated, and drain off the water inside.

#### 4JH3-TE series KMH4A Clutch

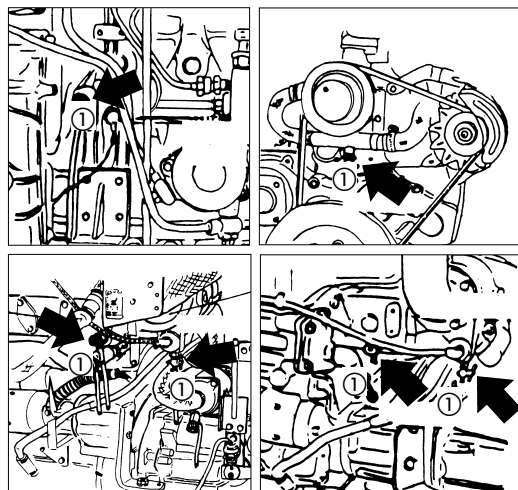

① Fresh water

### 3. Operation

(3) *Carry out the next periodic inspection before placing the engine in storage. Clean the outside of the engine wiping off any dust or oil.*

(4) *To prevent condensation inside the fuel tank, either drain off the fuel or fill the tank.*

(5) *Grease the exposed area and joints of the remote control cable and the bearings of the remote control handle.*

(6) *Cover the intake silencer, exhaust pipe, etc. with vinyl sheets and seal them to prevent moisture from entering.*

(7) *Drain bilge in the hull bottom completely. Water may leak into the boat when it is moored, and whenever possible it should be landed.*

(8) *Waterproof the engine room to prevent rain and seawater from entering.*

(9) *During long term storage, charge the battery once a month to compensate for the battery's self-discharge.*

#### **Checking the Engine for Reuse After a Long Storage Period**

When using the engine after a long period of storage, prepare for operation in the same manner as for a new engine. See 3.3.1

**GB**

## 4. Maintenance & Inspection

### 4.1 General Inspection Rules

#### Conduct Periodic Inspection for Your Safety.

The functions of engine components will degenerate and engine performance will drop according to the use of the engine. If countermeasures are not taken, you may encounter unexpected troubles while cruising at sea. Consumption of fuel or lube oil may become excessive and exhaust gas and engine noise may increase. These all shorten the life of the engine. Daily and periodic inspection and servicing increase your safety at sea.

#### Inspect Before Starting.

Make it a daily rule to inspect before starting. (See 3.3.1)

**GB**

#### Periodic Inspections at Fixed Intervals.

Periodic inspections must be made after every 50 hrs., every 250 hrs (1 yr.), every 500 hrs. (2 yrs.), every 1000 hrs. (4 yrs.) of use. Conduct periodic inspections according to the procedures described in this Operation Manual.

#### Use Genuine Parts.

Be sure to use genuine parts for consumable and replacement parts. Use of other parts will reduce engine performance and shorten the life of the engine.

#### Consult Your YANMAR Dealer or Distributor.

Specialized technicians are ready to assist you with periodic inspections and maintenance. Consult your YANMAR dealer or distributor in accordance with the service agreement.

#### Servicing Tools

Prepare servicing tools onboard to be ready for inspecting and servicing the engine and other equipment.

#### Tightening Torque of Bolts & Nuts

Over-tightening of bolts and nuts causes them to come off or their threads to be damaged. Insufficient tightening causes oil leakage from the installation face or troubles due to the loosening of bolts. Bolts and nuts must be tightened to the appropriate tightening torque. Important parts must be tightened with a torque wrench to the correct tightening torque and in the right order. Consult with your dealer or distributor if the servicing requires the removal of such parts.

The standard tightening torque for standard bolts & nuts is listed below.

### NOTICE

**Apply the following tightening torque to bolts having "7" on the head. (JIS strength classification: 7T)**

**Tighten bolts with no "7" mark to 60% tightening torque.**

**If the parts to be tightened are made from light alloy aluminum, tighten the bolts to 80% tightening torque.**

Bolt dia. × pitch mm	M6×1.0	M8×1.25	M10×1.5	M12×1.75	M14×1.5	M16×1.5
Tightening torque Nm	11 ± 01	26 ± 03	50 ± 05	90 ± 10	140 ± 15	230 ± 20

## 4. Maintenance & Inspection

### 4.2 List of Periodic Inspection Items

Daily and periodic inspections are important to keep the engine in its best condition. The following is a summary of inspection and servicing items by inspection interval. Periodic inspection intervals should vary depending on the uses, loads, fuels and lube oils used and handling conditions, and are hard to establish definitively. The following should be treated as a general standard only. Section 4.3 gives a detailed explanation of which parts must be inspected and the procedure for doing so for each interval.

## 4. Maintenance & Inspection

○: Check      ⊙: Replace      ●: Consult local dealer

System	Item	Before starting	After 50 hrs or one month	Every 250 hrs (1 year)	Every 500 hrs (2 years)	Every 1000 hrs (4 years)	
Fuel system	Check the fuel level, and refill	○					
	Drain the fuel tank		○ (first)		○		
	Drain the fuel filter		○				
	Replace the fuel filter			⊙			
	Check the injection timing					●	
	Check the injection spray condition				○		
Lubricating system	Check the lube oil level	Crankcase	○				
		Marine gear	○				
	Replace the lube oil	Crankcase		⊙ (first)	⊙		
		Marine gear		⊙ (first)	⊙		
	Replace the engine lube oil filter		⊙ (first)	⊙			
	Wash the lube oil filter (Marine gear)		○ (first)	○		○	
	Clean the engine oil cooler					●	
Clean the oil cooler (Marine gear)					●		
Cooling system	Seawater outlet	○ During operation					
	Check cooling water level	○					
	Check the impeller of the cooling water pump (seawater pump)			○		⊙	
	Replace the fresh water cooling		Every year				
	Clean & check the water passages					●	
Air intake and exhaust system	Clean the element of the air intake silencer			○			
	Clean the exhaust/water mixing elbow			○			
	Clean the breather pipe			○			
	Check the exhaust gas condition	○ During operation					
	Wash turbocharger blower			○			
Electrical system	Check the alarm lamps & devices	○					
	Check the electrolyte level in the battery		○				
	Adjust the tension of the alternator driving belt		○ (first)	○	⊙		
	Check the wiring connectors			○			
Cylinder head, etc.	Check for leakage of water and oil	○ (After starting)					
	Retighten all major nuts and bolts					●	
	Adjust intake/exhaust valve clearance		○ (first)		●		
Remote control system, etc.	Check/adjust the remote control operation	○		○			
	Adjust the propeller shaft alignment		○ (first)	○			

GB

## 4. Maintenance & Inspection

### 4.3 Periodic Inspection Items

#### 4.3.1 Inspection on Initial 50 Hrs. of Operation (or after 1 Month)

##### (1) Replacing the Engine Lube Oil and Lube Filter (1st time)

During initial operation of the engine, the oil is quickly contaminated due to the initial wear of internal parts. The lube oil must therefore be replaced early. Replace the lube oil filter at the same time.

It is easiest and most effective to drain the engine lube oil after operation while the engine is still warm.

1. Remove the lube oil dipstick. Attach the oil drain pump and drain off oil.
2. Remove the lube oil filter with the filter detach/attach tool. (Turn to the left.)
3. Clean the filter installation face and attach the new filter, tightening by hand.

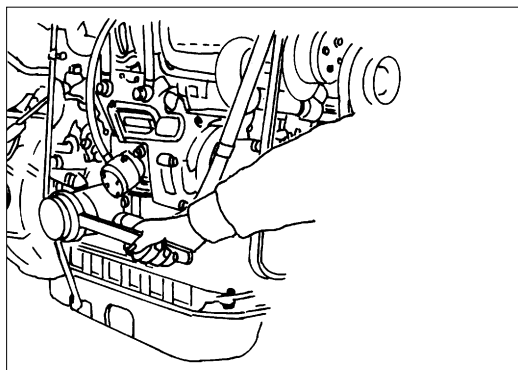

4. Turn an additional  $\frac{3}{4}$  of a turn with the attachment tool. (Turn to the right. Tightening torque: 20 ~ 24 Nm)
5. Fill with new lube oil. (See 3.2.3)
6. Perform a trial run and check for oil leakage.
7. Approximately 10 minutes after stopping the engine, remove the oil dipstick and check the oil level. Add oil if the level is too low.

### ⚠ CAUTION



Burns

##### (2) Replacing the Clutch Lube Oil and Cleaning the Clutch Filter (1st time)

During initial operation, the oil is quickly contaminated due to the initial wear of internal parts. The lube oil must therefore be replaced early.

1. Remove the cap from the filler port and attach the oil drain pump. Drain off oil. Clean the filter thoroughly with kerosene.
2. Fill with new lube oil. (See 3.2.4)
3. Perform a trial run and check for oil leakage.

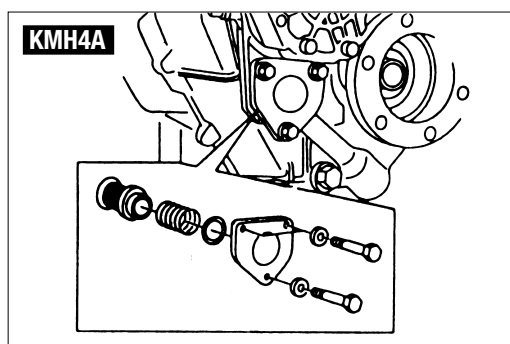

##### (3) Draining the (optional) Fuel Tank

Open the drain cock and drain off any water or dirt collected on the bottom. Put a pan under the drain to catch the fuel. Once the water and dirt has been drained off and the fuel coming out is clear, close the drain cock.

##### (4) Inspection and Adjustment of Intake/ Exhaust Valve Head Clearance (1st time)

Settling of a new engine and individual engine use will cause changes in the intake/exhaust valve and rocker arm clearance, and adjustment is necessary. This adjustment requires specialized knowledge and techniques. Consult your Yanmar dealer or distributor.

GB

## 4. Maintenance & Inspection

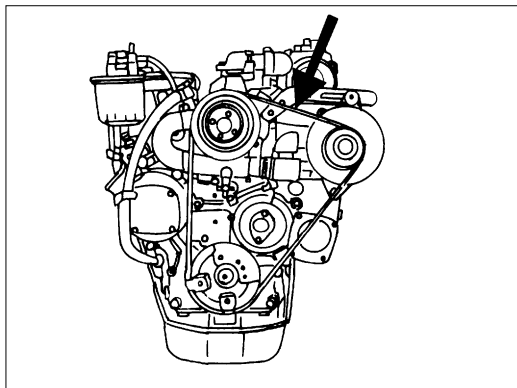

### (5) Adjusting the Tension of the Alternator Driving Belt.

When there is not enough tension in the V-belt, the alternator will not turn and power will not be generated.

When there is too much tension in the V-belt, the belt will become damaged more quickly, and the alternator bearing may be damaged.

1. Check the tension of the V-belt by pressing down on the middle of the belt with your finger.  
With proper flexion, the V-belt should sink 8~10mm.
2. Loosen the set bolt and move the alternator to adjust V-belt tension.
3. Be careful not to get any oil on the V-belt. Oil on the belt causes slipping and stretching. Replace the belt if it is marred.

### 4.3.2 Inspection Every 50 Hours (or Monthly)

#### (1) Draining the Fuel Filter

1. Close the fuel oil cock.
2. Loosen the plug screw at the bottom of the fuel filter oil/water separator, and drain off any water and dirt collected inside.  
Retighten the plug screw.
3. After reassembly, be sure to vent air from the fuel system. (See 3.2.2)
4. When there is a heavy deposit, drain the fuel tank at the same time.

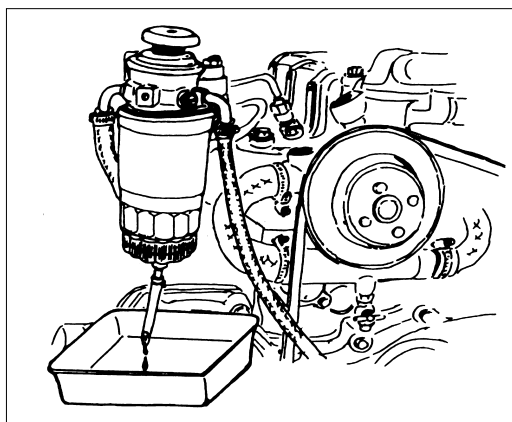

GB



## 4. Maintenance & Inspection

### (2) Electric Operation



Fire due to Electric Short-Circuits



Battery



Battery Fluid

#### **⚠ WARNING**

Before inspecting the electrical system, be sure either to turn off the battery switch or to disconnect the (-) terminal of the earth cable. Otherwise, a short-circuit could cause a fire.

Ensure good ventilation when charging the battery. The use of open flames is strictly prohibited. Hydrogen gas may also catch fire.

Battery fluid is diluted sulfuric acid. It can blind you or burn your eyes or skin. Wear goggles and gloves when handling battery fluid. Should the fluid be deposited on your skin, wash with a large quantity of fresh water and seek treatment from a doctor.

1) *If operation continues with insufficient battery fluid, the battery will be destroyed. Check the fluid level periodically. If the level is lower than specified, resupply battery fluid (available in the market) up to the upper limit of the battery.*

(Battery fluid tends to evaporate in high temperatures, especially in summer. In such cases, inspect the battery earlier than specified.)

2) *If the engine speed will not rise and the engine cannot be started, measure the specific gravity with a pycnometre (available in the market).*

The specific gravity of the fluid when fully charged is over 1.27 (at 20°C).

Fluid with a specific gravity of below 1.24 needs charging. If the specific gravity

cannot be raised by charging, the battery must be replaced.

#### **NOTICE**

The capacities of the standard alternator and the recommended battery assume only the power necessary for regular operation. If the power is also used for inboard lighting or other purposes, the generating and charging capacities may be insufficient. In such cases, consult your Yanmar dealer or distributor.

### 4.3.3 Inspection Every 250 hours.

#### (1) Replace the engine oil and the clutch lube oil.

After the second oil change, the engine oil should be replaced after every 250 hours.

#### (2) Replacing the Engine Oil and Lube Oil Filter

(See 4.3.1(1))

#### (3) Adjusting the Remote Control Cable

The various control levers on the engine side are connected to the remote control lever by the remote control cable. The cable will become stretched and the attachments loose after long hours of use causing deviation. It is dangerous to control operation under these conditions, and the remote control cable must be checked and adjusted periodically.

##### A) *Adjusting the Governor Remote Control Cable*

Check to see that the control lever on the engine side moves to the high speed bolt position and low speed bolt position when the remote control lever is moved to H (high speed) and L (low speed) respectively.

When there is deviation, loosen the bracket for the remote control cable on the engine side and adjust.

**GB**

## 4. Maintenance & Inspection

Adjust the high speed bolt position first and then adjust the low speed idling.

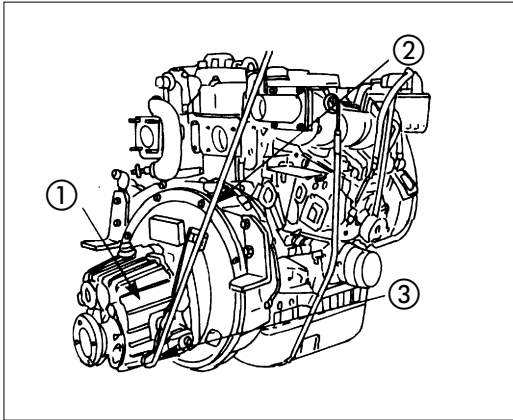

① Marine gear ② Cable ③ Adjustment

1. Close the fuel cock.
2. Remove the filter case by loosening the retainer ring (turn to the left) with the filter wrench.
3. Pull the element out from the bottom, and replace with a new one.
4. Clean the inside of the case thoroughly, put on the O-ring, and close with the retainer ring. (Turn to the right. Tightening torque: 12 Nm)
5. Air will enter into the fuel system when the filter is disassembled, and should be vented. (See 3.2.2)

### (5) Cleaning the Intake Silencer

Disassemble the intake silencer and clean the inside thoroughly. Remove the cover by taking off the clamp. Clean the element with a neutral detergent. Reassemble after it is completely dry.

### (6) Adjusting the Tension of the Alternator Driving Belt

(See first 50 hrs.)

**GB**

### B) Adjusting the Clutch Remote Control Cable

Check to see that the control lever moves to the correct position when the remote control handle is put in NEUTRAL, FORWARD, REVERSE.

Use the NEUTRAL position as the standard for adjustment. When there is deviation, loosen the bracket for the remote control cable on the clutch side and adjust.

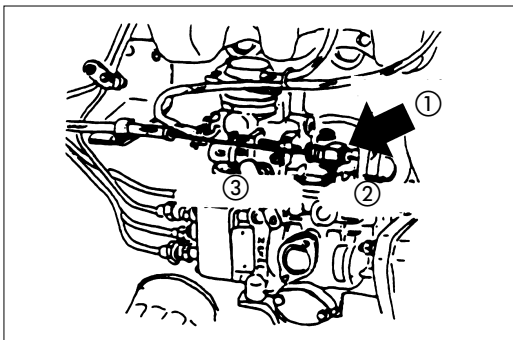

① Speed lever ② Low speed ③ High speed

### (4) Replacing the Fuel Filter

When there is dirt in the fuel, the filter becomes clogged, and the fuel will not flow easily. Check and replace the inside element.

## 4. Maintenance & Inspection

### (7) Inspecting Inner Parts of the Seawater Pump

Depending on the use, the inside parts of the seawater pump deteriorate and discharge performance drops. At the specified interval or when the volume of seawater discharged is reduced, inspect the seawater pump in accordance with the following procedures:

1. Loosen the side cover set bolts and remove the side cover.
2. Illuminate the inside of the seawater pump with a flashlight and inspect.
3. If any of the following problems is found, disassembly and maintenance are necessary:

a) *Impeller blades are cracked or nicked. Edges or surfaces of the blades are marred or scratched.*

*Note:* The impeller must be replaced periodically (every 1000 hrs.).

b) *Wear plate is damaged.*

4. If no damage is found when inspecting the inside of the pump, reassemble the side cover.  
Fit the O-ring to the groove of the joint face before replacing the side cover.  
If a large amount of water leaks continuously from the water drain pipe beneath the seawater pump during operation, disassembly and maintenance (replacement of the oil seal) are necessary.  
When disassembly and maintenance of the seawater pump are necessary, consult your Yanmar dealer or distributor.

### **NOTICE**

**The seawater pump turns in the counterclockwise direction, but the impeller must be installed by turning in the clockwise direction. If the impeller has been removed for any reason and must be reassembled, be very careful not to make a mistake and turn it in the wrong direction. Additionally, if the engine is being turned manually, be careful to turn it in the correct direction. Incorrect turning will twist the impeller and damage it.**

### (8) Washing the Turbocharger Blower

When engine revolution seems sluggish or the exhaust colour poor, the blades of the turbocharger blower may be dirty. Wash the blower in the following manner:

1. Have ready blower wash (liquid detergent), fresh water, and a small pitcher.
2. Put the clutch in neutral and run the engine at high speed (2500~3000rpm).
3. Slowly pour approximately 50cc of blower wash into the turbocharger suction inlet over a period of about 10 seconds.

### **NOTICE**

**Do not pour in a large amount of blower wash at one time (pour it in gradually) as this can damage the blower blades and get water hammer in the combustion chamber leading to accidents.**

4. After about 3 minutes, pour in approximately 50cc of fresh water in the same manner over a period of about 10 seconds.

**GB**

## 4. Maintenance & Inspection

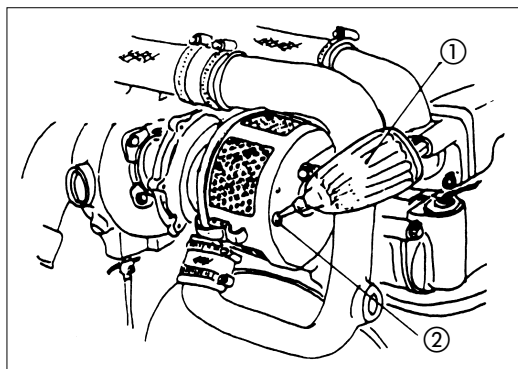

① Blower wash    ② Inlet

5. After operating the engine for about 10 minutes, check the boost pressure and power output.

If there is no improvement after washing the blower, repeat the washing process several times.

If there is still no improvement consult your local Yanmar dealer.

**GB**

### 4.3.4 Inspection every 500 hrs.

#### (1) Draining the fuel tank.

(See first 50 hrs.)

#### (2) Inspecting and Adjusting the Fuel Injection Spray Condition.

Adjustment is necessary to obtain the optimal fuel injection to ensure the best possible engine performance. This inspection requires specialized knowledge and techniques. Consult your Yanmar dealer or distributor.

#### (3) Replace Driving Belt

(See first 50 hrs.)

#### (4) Inspection and Adjustment of Intake/ Exhaust Valve Clearance.

When operating for long periods of time, the clearance between the intake/exhaust valve and the rocker arm will change and affect operation performance. Adjustment is necessary.

Adjustment requires specialized knowledge and techniques. Consult your Yanmar dealer or distributor.

#### (5) Adjusting the Remote Control Cable (See 4.3.2(3))

### 4.3.5 Inspection Every 1000 hrs.

#### (1) Inspecting and Adjusting the Fuel Injection Timing

Fuel injection timing must be adjusted to ensure optimal engine performance.

This maintenance requires specialized knowledge.

Consult your Yanmar dealer or distributor.

#### (2) Washing the Cooling Water System and Checking and Maintaining Parts

This maintenance requires specialized knowledge. Consult your Yanmar dealer or distributor. Over time rust and scale builds up in the seawater and fresh water systems, reducing their cooling performance. Additionally, when the inside of the engine oil cooler and the clutch oil cooler become dirty, lube oil cooling worsens causing the oil to deteriorate more quickly.

Wash the following related parts when the cooling water is being replaced.

Cooling water system related parts: seawater pump, engine oil cooler, clutch oil cooler, fresh water pump, fresh water cooler, thermostat, etc.

#### (3) Replace Impeller of Seawater Pump

(See 250 hrs.)

## 5. Trouble and Troubleshooting

### 5.1 Trouble and Troubleshooting

Trouble	Probable Cause	Measure	Reference
<b>Alarm Buzzer and Alarm Lamps On During Operation</b>	<p><b>NOTICE</b></p> <p>Shift to low speed operation immediately, and check which lamp has come on. Stop the engine for inspection. If no abnormality is identified and there is no problem with operation, return to port at your lowest speed and request repairs.</p>		
<b>Eng.Lube Oil Press. Warning Lamp goes on</b>	Engine Lube Oil insufficient; Fuel filter clogged.	Check Lube Oil level. Replenish or replace.	3.2.3 4.3.1(1)
<b>C.W.Temp.(Fresh Water) warning lamp goes on</b>	Insufficient water in fresh water cooler. Insufficient seawater causing temp. to rise. Contamination inside cooling system.	Check cooling water and replenish. Check seawater system. Ask for repairs.	3.2.5
<b>Faulty Warning Devices</b>	<p><b>NOTICE</b></p> <p>Do not operate the engine if alarm devices are not repaired. Serious accidents may result if difficulties are not spotted due to faulty alarm lamps. When switch is turned ON: Alarm buzzer does not sound. Circuit broken or buzzer defective. Ask for repairs.</p>		
<b>C.W. Level Alarm Lamp goes on</b>	Insufficient cooling water in fresh water tank.	Check and replenish fresh cooling water.	3.2.5
<b>Fuel Filter Alarm Lamp goes on</b>	Increased fuel filter drain.	Drain the fuel filter.	4.3.2(1)
<b>Exhaust Alarm Lamp goes on</b>	Insufficient discharge of cooling seawater. Damaged cooling seawater pump.	Kingston cock is closed. Kingston cock is clogged. Suction hose is damaged or joints are loose. Check seawater pump impeller.	4.3.3(7)
<b>One of the warning lamps does not go out</b>	Sensor switches faulty.	Ask for repairs.	
<b>Charge lamp does not go out during operation (Buzzer does not sound)</b>	V-belt is loose or broken. Battery defective. Alternator power generator failure.	Replace V-belt; adjust tension. Check fluid level, specific gravity; replace. Ask for repairs.	4.3.1(3) 4.3.2(4)

\*Note: Other warning lamps do not go on when the switch is turned on. They only go on when there is an abnormality.

GB

## 5. Trouble and Troubleshooting

Trouble	Probable Cause	Measure	Reference
<b>Starting Failures</b>			
<b>Starter turns, but engine does not start</b>	No fuel. Fuel filter is clogged. Improper fuel. Faulty fuel injection. Compression leakage from intake/exhaust valve.	Replenish fuel; vent air. Replace element. Replace with recommended fuel. Ask for repairs. Ask for repairs.	3.2.2 4.3.4(1)
<b>Starter does not turn or turns slowly (Engine can be turned manually)</b>	Faulty clutch position. Insufficient battery charge. Cable terminal contact failure. Faulty safety switch device. Faulty starter switch. Power lacking due to other use.	Shift to NEUTRAL and start. Check fluid lever; recharge; replace. Remove rust from terminal; retighten. Ask for repairs. Ask for repairs. Ask for repairs. Consult your dealer.	3.3.2(1) 4.3.2(4)
<b>Engine cannot be turned manually</b>	Internal parts seized; broken.	Ask for repairs.	
<b>Abnormal Exhaust Colour Black smoke</b>	Load increased. Contaminated intake silencer. Boost pressure low. Improper fuel. Faulty spraying of fuel injection valve. Incorrect intake/exhaust valve head clearance.	Inspect propeller. Clean element. Wash turbocharger blower. Replace with recommended fuel. Ask for repairs. Ask for repairs.	4.3.4(4) 4.3.3(8) 3.1.1
<b>White smoke</b>	Improper fuel. Faulty spraying of fuel injection valve. Fuel injection timing off. Lube oil burns; excessive consumption.	Ask for repairs. Ask for repairs. Ask for repairs. Ask for repairs.	3.1.1

GB

### NOTICE

When the clutch is broken **KMH4A**:  
See 5.2, Emergency Repairs for Clutch Trouble.

### 5.2 Emergency Repairs for Clutch. KMH4A Marine Gear Only

In case of emergency, follow the following procedure for using the clutch emergency bolt to return to port.

### NOTICE

- Using the emergency bolt directly connects the clutch to the engine making it possible to turn the propeller. However, when the engine is started and the propeller turns, the boat will only move forward. The neutral and reverse positions cannot

be used.

The emergency bolt should only be used in cases where it is impossible to operate the clutch and the boat must return to port. Ask your Yanmar dealer for repairs immediately after returning to port.

- When using the emergency bolt, never use the clutch as this will break it.
- Operate at low speed, 1000rpm or less, and navigate carefully.  When approaching the pier turn off the engine early and stop the boat.

Perform the following steps after turning off the engine:

1. Remove the hexagonal red bolts at the back of the clutch with a spanner.

## 5. Trouble and Troubleshooting

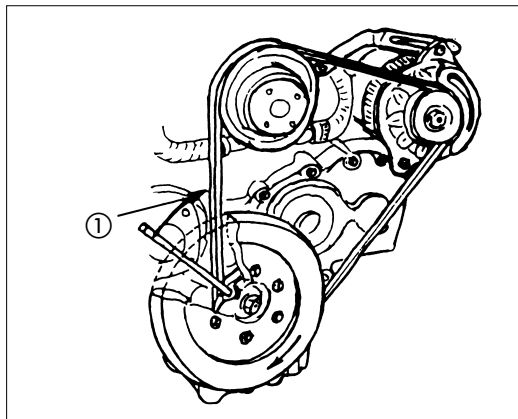

① Turning stick direction

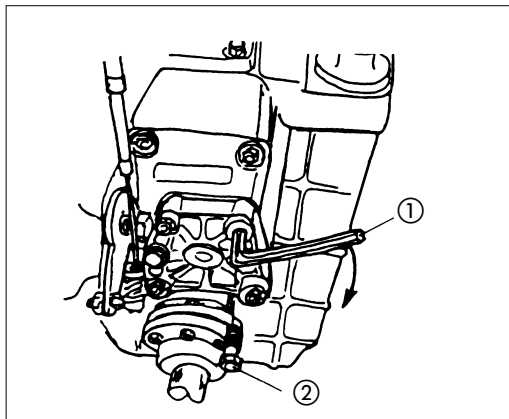

① Emergency bolt tightening tool  
② Bolt (red)

2. Check to see if the emergency bolt is visible at the back of the bolt hole. When the emergency bolt is not visible, insert a turning stick little by little in the holes at the front side of the V-pulley, turning it in the direction of the crank shaft rotation and stopping when the emergency bolt becomes visible.
3. Inset the emergency bolt tightening tool into the bolt hole and tighten the emergency bolt.
4. There are 2 emergency bolts. Follow the procedure described in 2 and 3 for the second bolt, and tighten the

- bolts alternately applying the same amount of force to each. (Tightening torque: 19 ~ 01 Nm)
5. Replace the hexagonal bolt.
6. Fill with the clutch oil set aside for emergencies to the mouth of the filler port. (When the oil pump is not working, there is no lubrication and filling with oil is essential.)
7. Start the engine with the clutch handle in neutral and proceed at low speed.

**GB**

### Consulting Your Yanmar Dealer or Distributor

Refer difficult problems and repairs to your Yanmar dealer or distributor. At the time of trouble, check and report the following:

1. Engine model and number:
2. Boat name, material of hull, size (tons):
3. Use, type of fishing done, no. of hours run:
4. Total no. of operation hours (refer to hour metre), age of boat:
5. Condition before trouble (engine rpm, type of operation, load condition, etc.):
6. Details of trouble:  
(exhaust colour; sound of engine; does engine start; can engine be turned manually; type of fuel used; brand and viscosity of lube oil; etc.)
7. Past problems and repairs:

## 5. Trouble and Troubleshooting

### WARRANTY SERVICE

#### Owner Satisfaction

Your satisfaction and goodwill are important to us and to your dealer.

Normally any problems concerning the product will be handled by our dealer's service department. If you have a warranty problem that has not been handled to your satisfaction, we suggest you take the following action:

- Discuss your problem with a member of the dealership management. Complaints can often quickly be resolved at this level. If the problem has already been reviewed with the Service Manager, contact the owner of the dealership or the General Manager.
- If your problem still has not been resolved to your satisfaction, contact your local Yanmar Subsidiary Company. (See the back of this manual for addresses)

We will need the following information in order to assist you:

- Your name, address and telephone number
- Product model and serial number
- Purchase date
- Dealer's name and address
- Nature of the problem

After reviewing all the facts involved, you will be advised of what action can be undertaken. Please remember that your problem will most likely be resolved at the dealership, using the dealer's facilities, equipment and personnel. It is therefore very important that your initial contact be with the dealer.

**GB**



## 6. Piping diagram

(See appendix A at the back of this book)

NOTATION	
RH	Rubber hose
SGP STS	Steel pipe
C1201T	Copper pipe
⊕—	Screw joint (Union)
⊕—	Flange joint
⊕—	Eye joint
—<	Insertion joint
====	Drill hole
----	Cooling fresh water piping
----	Cooling seawater piping
---	Lubricating oil piping
—	Fuel oil piping

- 1 Overflow
- 2 Fuel oil inlet
- 3 Piston cooling oil jet
- 4 Fuel injection pump
- 5 Lub. oil filter (cartridge type)
- 6 Fuel high pressure pipe
- 7 Fuel injection nozzle
- 8 Oil pressure switch
- 9 Lub. oil cooler
- 10 Mixing elbow
- 11 Fresh water cooler
- 12 Lub. oil inlet filter
- 13 Main bearing
- 14 Seawater inlet
- 15 Cooling water pump (seawater)
- 16 Hot water connection outlet
- 17 Thermostat
- 18 Cooling water pump (fresh water)
- 19 Hot water connection inlet
- 20 Fresh water temperature switch
- 21 Lub. oil pump
- 22 Pressure control valve
- 23 Clutch lube oil cooler
- 24 Turbo charger
- 25 Seawater outlet
- 26 Air cooler\*
- 27 Fuel oil filter (cartridge type)

\* Not applicable (for the TE-model)

### NOTES:

Dimension of steel pipe:  
outer dia.x thickness  
Dimension of rubber pipe:  
inner dia. x thickness

Note: This piping diagram is for the 4JH3E model.

**GB**

## 7. Wiring diagrams

(See appendix B at the back of this book)

Colour coding for wiring diagrams	
R	Red
B	Black
W	White
Y	Yellow
L	Blue
G	Green
O	Orange
Lg	Light green
Lb	Light blue
Br	Brown
P	Pink
Gr	Grey
Pu	Purple

### For B/C-type panel

- |  |  |
|--|--|
| 1 Starter switch                       | 24 Option                                    |
| 2 Stop switch                          | 25 Instrument panel                          |
| 3 Switch (lamp chk/illum.)             | 26 Buzzer                                    |
| 4 Relay                                | 27 Tachometre                                |
| 5 Relay (optional)                     | 28 Not applicable                            |
| 6 Engine stop solenoid (optional)      | 29 Oil pressure                              |
| 7 Procured by customer                 | 30 Cooling Fresh Water temp.                 |
| 8 (Cross sectional area)               | 31 Charge                                    |
| 9 Battery switch                       | 32 Switch (lamp chk/illum.)                  |
| 10 Battery                             | 33 Starter switch                            |
| 11 Air heater                          | 34 Stop switch                               |
| 12 Starter relay*                      | 35 Instrument panel (No.2 station)(optional) |
| 13 Starter                             | 36 Tachometre                                |
| 14 Cooling water temperature switch    | 37 Buzzer                                    |
| 15 Engine oil pressure switch          | 38 Water proof                               |
| 16 Alternator                          | 39 Oil pressure                              |
| 17 Earth bolt                          | 40 Cooling Fresh Water temp.                 |
| 18 Not applicable                      | 41 Charge                                    |
| 19 Tachometre sensor                   | 42 Buzzer switch                             |
| 20 (Cooling water temperature sender)  | 43 FUSE (3A)                                 |
| 21 Engine oil pressure sender          | 44 Eng. oil pressure metre                   |
| 22 Wire harness for 2 panel (optional) | 45 Cooling water temp. metre                 |
| 23 Wire harness (optional)             | 46 Hour metre                                |
|  | 47 Illumination switch                       |
|  | 48 Cooling water temp.                       |
|  | 49 Eng. oil pressure                         |

\* Note: When using extension wireharnesses of more than 6m, the starter relay connection is as shown here.

- MANUFACTURER'S DECLARATION FOR MACHINERY PARTS ACCORDING TO 94/25/EEC(ANNEX-15) & 89/336/EEC
- MANUFACTURER: YANMAR CO., LTD.  
1-32, Chayamachi, Kita-ku, Osaka, Japan
- DESCRIPTION OF THE MACHINERY PARTS
- CATEGORY: Diesel engine
  1. MAKE: YANMAR
  2. THIS MACHINERY PART MUST NOT BE PUT INTO SERVICE UNTIL THE MACHINERY INTO WHICH IT IS TO BE INCORPORATED HAS BEEN DECLARED IN CONFORMITY WITH THE PROVISIONS OF THE DIRECTIVE.
- IMPORTER IN THE EU: YANMAR MARINE INTERNATIONAL B.V.  
Brugplein 11  
1332 BS Almere-de Vaart, The Netherlands



Nagahama, Japan, Sept. 21, 1997  
Place and date issued

---

Y. Sugita  
Manager  
Quality Assurance Dept.  
Power System Operation Div.